

KRAUS

Eine Idee voraus



We get things rolling...

CONVEYOR ROLLERS

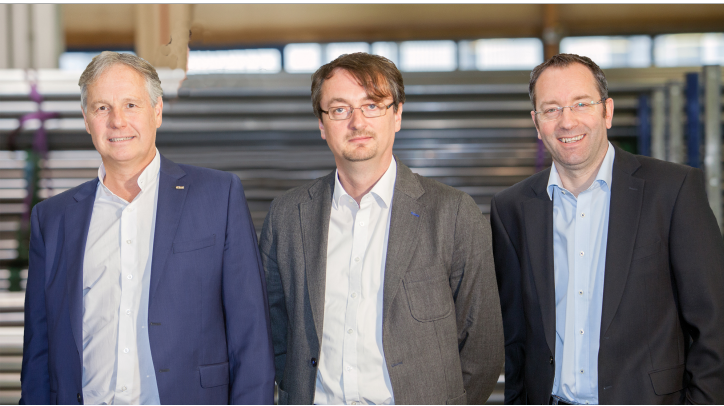

We get things rolling...

For 70 years, many national and international companies such as Porsche, Vienna International Airport, Coca Cola, or Swarovski have trusted in high-quality rollers from our in-house production - "MADE IN AUSTRIA."

Because of their high reliability and excellent quality, and because our price-performance ratio is unmatched, KRAUS conveyor rollers are found in numerous transport and conveying applications around the world. No job is too small for us; no challenge is too great for us. We would be delighted to count your company among our customers. Our experienced technicians gladly advise you, even at your location. Fast response time and flexibility are our strengths.

A handwritten signature in black ink that reads "D. Wagner". The signature is stylized and fluid.

Dieter Wagner
Managing Partner





CONTENT

Quality, innovation, team-spirit	Page 5
Together we are strong!	Page 6
Kraus international	Page 8
Planning and production	Page 10
Consulting, planning und service	Page 12
conveyor rollers overview	Page 14
Gravity rollers	Page 16
SERIES 500, 1000	Page 17
SERIES 2000	Page 18
SERIES 2500, 2600	Page 19
SERIES 3700	Page 20
Driven rollers	Page 22
SERIES 3760	Page 23
SERIES 4830, 5170	Page 24
SERIES 4840	Page 25
SERIES 4900	Page 26
SERIES 4550, 5070	Page 27
SERIES 5020	Page 28
SERIES 5103, 5104, 5105	Page 29
SERIES 5113, 5115	Page 30
SERIES 5123, 5125	Page 31
Conical rollers	Page 32
SERIES 6000, 6020, 6560, 6040	Page 33
Special orders	Page 34
Drive rollers	Page 36
World Wide Web	Page 38
Checklist	Page 39

QUALITY

The conveyor roller is the most important component of many transportation solutions. We manufacture conveyor rollers at our own in-house production facility! We produce with modern systems and machine using quality-tested materials and no Kraus roller leaves the production facility unchecked.



INNOVATION

The slogan „one idea ahead“ brings our company’s philosophy to the point. Innovation means to improve what already exists and propel forward new developments. Our latest coup: the motor roller Omega 50. See page 36 - 37.

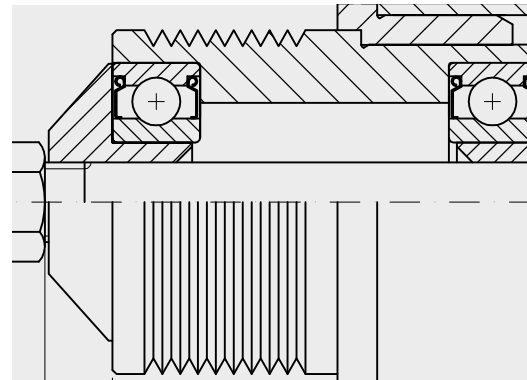

TEAM SPIRIT

...is more than just a slogan at Kraus! Kraus is proud of its highly trained staff. For our team, no job is too small and no challenge too great. This is why Kraus also relies on continuously training its employees.



CONTACT

Order processing:	direct contact	Technical questions	direct contact
Phone number:	+43 (0) 463/3860-30	Phone number:	+43 (0) 463/3860-29
Phone number:	+43 (0) 463/3860-36	Phone number:	+43 (0) 463/3860-48
Fax number	+43 (0) 463/3860-54	Phone number:	+43 (0) 463/3860-76

www.kraus.co.at
conveyorroller@kraus.co.at

TOGETHER WE ARE STRONG!

For over 70 years, numerous top national and international companies have been relying on tailor-made solutions from the company KRAUS.

For this reason, the Carinthian company Kraus today has an excellent reputation in the area of internal goods and materials logistics and transportation - even beyond the borders of Austria. Take advantage of the Kraus know-how and become one of our many satisfied customers.

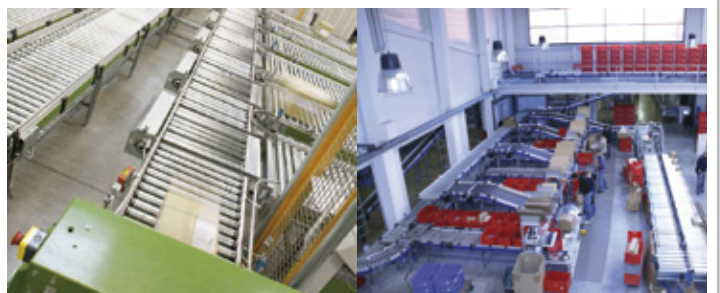
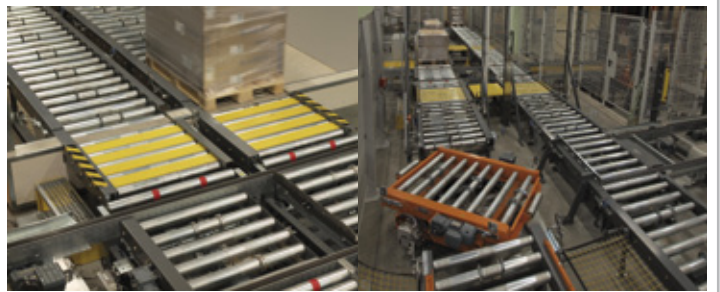



KRAUS INTERNATIONAL

We are present across Europe with many local partners and are sure to be in your area as well.

Benefit from our experienced technicians providing professional advice on site. We will gladly come to your operation location for a free consultation.

Call the number below to arrange a consultation meeting:

Phone: **+43 (0) 463 38 60 - 0**

Email: conveyorroller@kraus.co.at



- **GERMANY**
- **DENMARK**
- **CZECH REPUBLIC**
- **SLOVAKIA**
- **ROMANIA**
- **SLOVENIA**
- **SERBIA**
- **CROATIA**
- **SWITZERLAND**
- **HUNGARY**

A large, blue, 3D-style logo of the word 'kraus' is mounted on the roof of a building. The building has a grey, horizontally-slatted facade. A large, dark blue diagonal stripe runs across the facade. The sky is blue with white clouds. On the right side of the image, there is a white outline of a map of Europe, with a small inset image showing a landscape with trees and a building.





PLANNING & PRODUCTION

we turn your ideas into reality

SALES CONSULTING

Kraus offers free professional consulting on site.

You need expert advice to pick the right conveyor roller for your specific needs or application from a total of 1500 different roller versions. Our conveyor roller sales team makes sure you find the optimal solution.



PLANNING

If requested, we also gladly take care of your specific requirements.

Our competent planning team will help you to find you the best and most economical solution. KRAUS uses central production planning to coordinate and plan capacities for each individual work step.

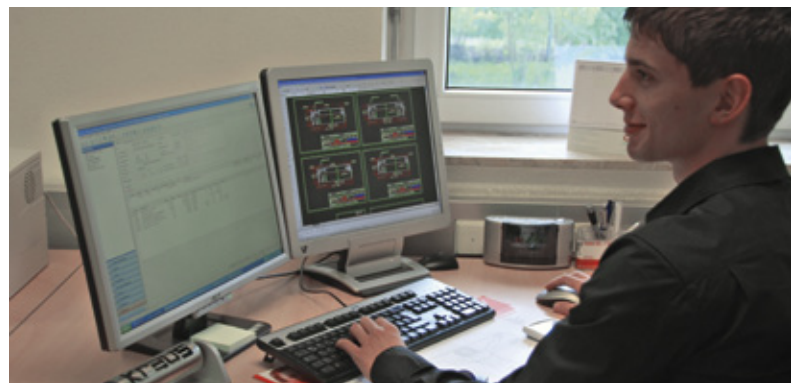

PRODUCTION

KRAUS fills each order specifically as stipulated by customer requirements.

The production of a conveyor roller consists of 6 to 8 process steps and has a lead time of 6 to 8 days. From cutting to assembly, each production step is carefully planned to make sure we meet and exceed the requirements and specifications of our customers.



QUALITY CONTROL

Kraus combines years of experience with modern manufacturing technology.

We use only selected, quality-tested materials for the production of our high-quality conveyor rollers. No conveyor roller leaves our house before it was inspected and approved by our quality control department.



CONSULTING

Our consulting team consists of highly qualified mechanical engineers and is based on the needs and requirements of our customers. The satisfaction of our customers is our top priority.

Our mission is to find the best and most economical solution for you. Contact us via Internet or talk to us by phone or locally in person for answers to your technical questions. Involved early on in your project planning, we help you to develop the most efficient and optimized solution. Our innovative ideas with proven components ensure our success and lead us to your desired solution.



PLANNING

We are working with you to find the optimal roller for your specific application.

Our creative staff will use their flexibility and commitment to develop for you the best-possible customer-based and user-oriented solutions. Practical experiences are the basis for ideas and improvements that are continuously integrated into our product development.

We turn customer wishes into reality - from prototype to series production.

- **Short response times**
- **Highest quality standards with our own production facility**
- **Maximum efficiency due to optimal planning times and short lead times**



SERVICE

Individual service: If requested, we also gladly take care of your special requirements.

Profit from our know-how as a manufacturer and take advantage of the services of our consultants. We provide you with the exact delivery date as early as submitting an offer. If requested, we can implement scheduled transports fixed delivery terms to your facility or any other destination.



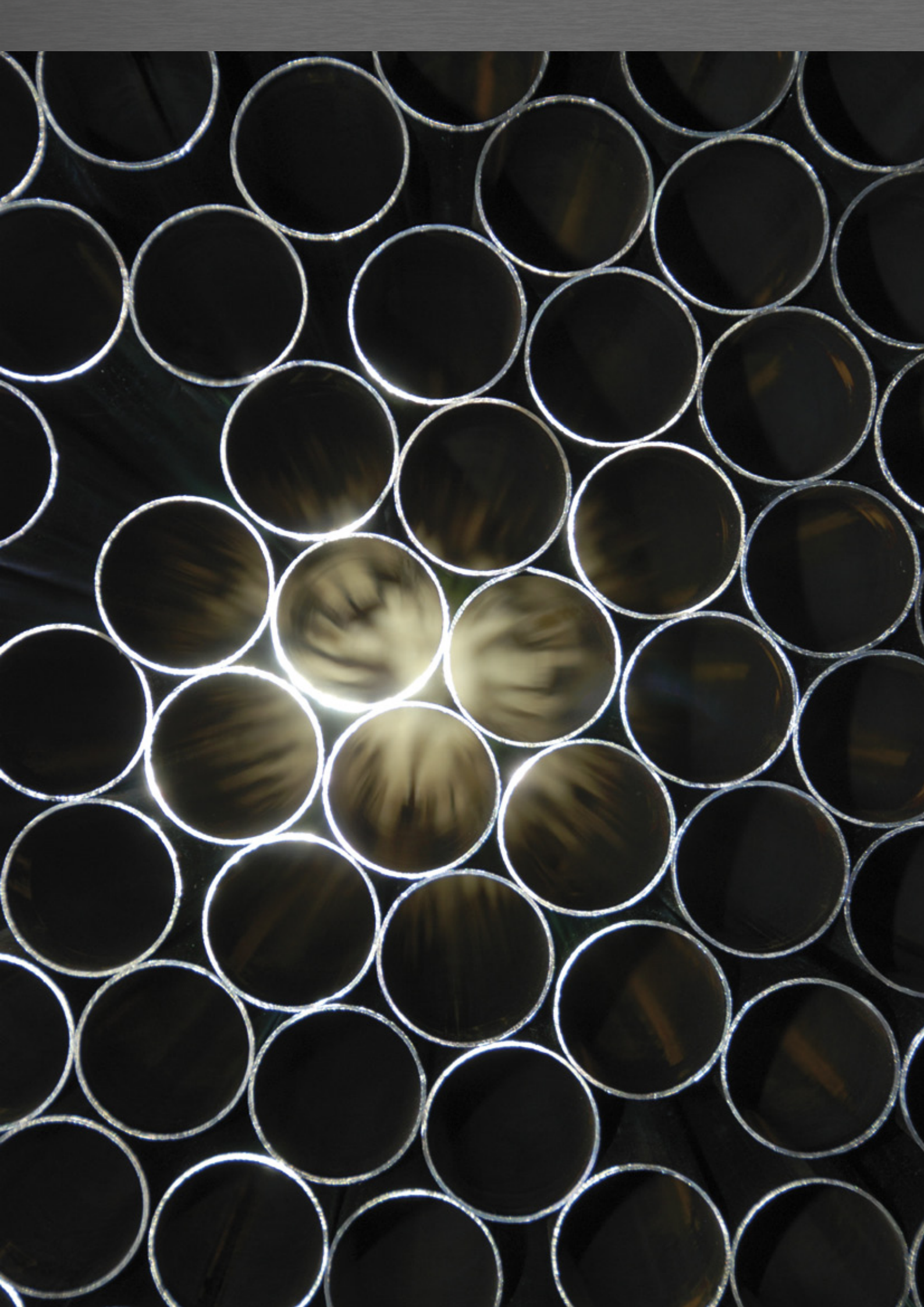

CONVEYOR ROLLER OVERVIEW

The conveyor roller is the most important component of many transportation solutions. Therefore, we will personally make sure you get the best quality rollers possible:

We manufacture conveyor rollers at our own in-house production facility! We produce with modern systems, use quality-tested

materials, and rely on ongoing employee training. This had made it possible for us to acquired a reputation as a reliable and competent partner - far beyond the borders of Austria.



GRAVITY ROLLERS

Gravity conveyor rollers for applications with manual drive or by gravity

- For light and heavy piece goods
- In many different versions and for various purposes
- Made of steel, plastic, aluminum and stainless steel



DRIVEN ROLLERS

Motorized rollers for round belts, applications with serpentine belts, timing belts, or chain drive

- For light and heavy piece goods
- Different types ensure such properties as low-noise running, protection against dust and splash water, transportation that is gentle to the material



CONICAL ROLLERS

Conical conveyor rollers for the safe transport of piece goods in curves

- Gravity conical rollers
- Conical rollers with chain drive
- Conical rollers with round belt drive
- Conical rollers with serpentine belt drive



SPECIAL ORDERS

Of the total volume of conveyor rollers produced by us, 20% are strictly manufactured according to customer specifications

- **Special orders specifically tailored to the needs of the customer**
- **Material-independent**
- **Can be used for existing processes**
- **Rubberized conveyor rollers**

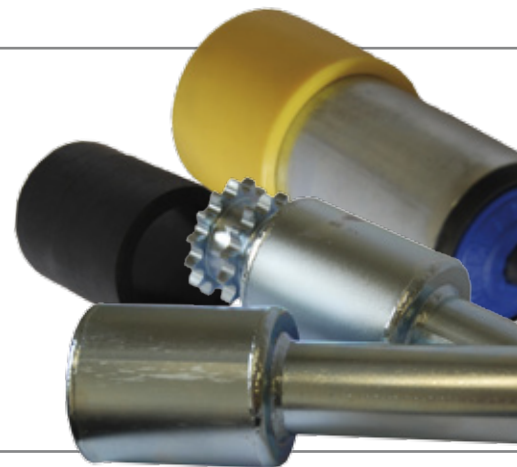

DRIVE ROLLERS

Designed specifically for container transport

- **No gear**
- **Silent drive**
- **Many drive possibilities due to a variety of drive heads**

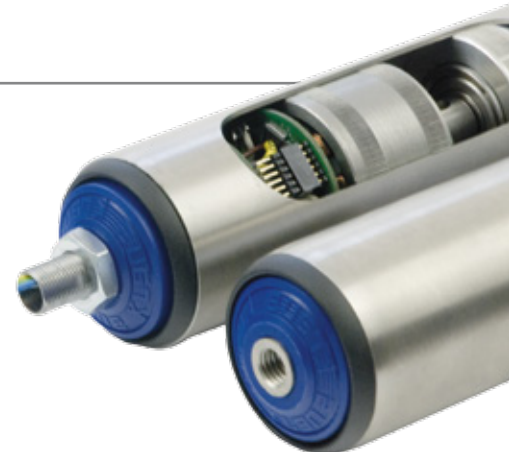

GRAVITY ROLLERS

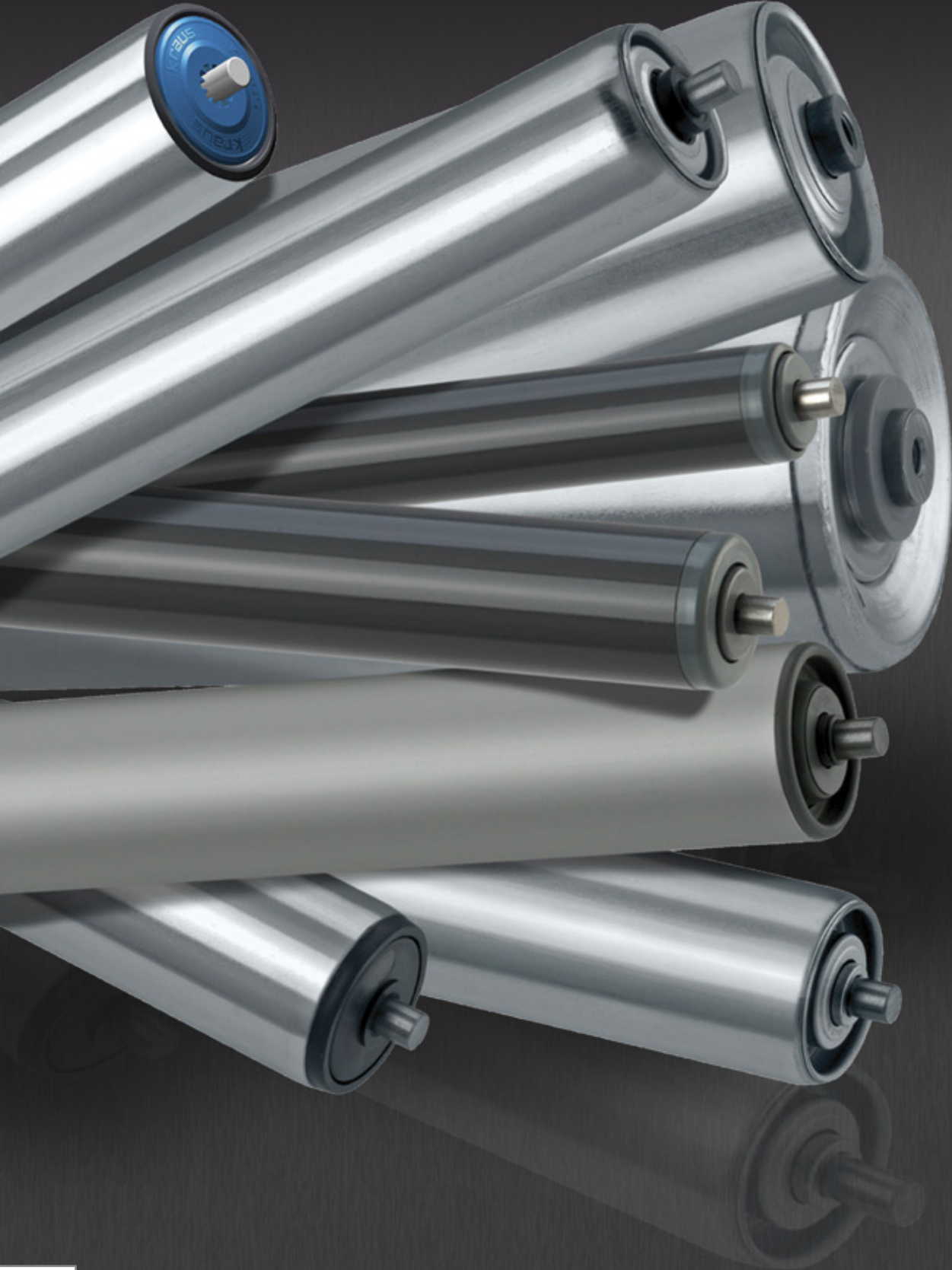



SERIES 500

SERIES 1000

SERIES 500 - CONSTRUCTION WITH EXTERNAL THREAD

tube- \varnothing (mm)	axle- \varnothing (mm)	6	8	10
\varnothing 20 \varnothing 30 \varnothing 40	external thread:	M 6x25	M 8x25	M 10x25
	tubelenght =	EBL -32	EBL -35	EBL -37
	rollerlenght =	EBL -16	EBL -19	EBL -21
	axlelenght =	EBL +30		

SERIES 500 - CONSTRUCTION WITH INTERNAL THREAD

tube- \varnothing (mm)	axle- \varnothing (mm)	8	10
\varnothing 20 \varnothing 30 \varnothing 40	internal thread:	M 5x15	M 6x15
	tubelenght =	EBL -21	
	rollerlenght =	EBL -5	
	axlelenght =	EBL +20	

SERIES 1000 - CONSTRUCTION WITH EXTERNAL THREAD

tube- \varnothing (mm)	axle- \varnothing (mm)	6	8	10	12
\varnothing 50	external thread:	M 6x15	M 8x15	M 10x15	M 12x15
	tubelenght =	EBL -25	EBL -28	EBL -30	EBL -33
	rollerlenght =	EBL -19	EBL -22	EBL -24	EBL -27
	axlelenght =	EBL +30			

SERIES 1000 - CONSTRUCTION WITH INTERNAL THREAD

tube- \varnothing (mm)	axle- \varnothing (mm)	8	10	12
\varnothing 50	internal thread:	M 5x15	M 6x15	M 8x15
	tubelenght =	EBL -14		
	rollerlenght =	EBL -8		
	axlelenght =	EBL		

ADVANTAGES:

- Cost-effective
- Free running
- Low inherent weight
- Option for corrosion-resistant construction

APPLICATION:

- For in-plant conveyor systems
- Temperature-resistant from -10°C to + 40°C

MAX. DYNAMIC CARRYING CAPACITY:

- conveyor roller \varnothing 20 – 0,10 kN
- conveyor roller \varnothing 30 – 0,15 kN
- conveyor roller \varnothing 40 – 0,15 kN
- conveyor roller \varnothing 50 – 0,20 kN

MAX. CONVEYOR SPEED

- 0,3 m/s for conveyor roller \varnothing 20, \varnothing 30
- 0,5 m/s for conveyor roller \varnothing 40, \varnothing 50

TUBE DIMENSIONS:

galvanized steel tube in accordance with DIN 2394
 galvanized: \varnothing 20 x 1,5; \varnothing 30 x 1,5; 40 x 1,5; 50 x 1,5
 PVC-tube: \varnothing 20 x 1,5; \varnothing 30 x 1,8; \varnothing 40 x 2,3; 50 x 2,8
 V2A-tube: \varnothing 20 x 1,5; \varnothing 30 x 1,0; 40 x 1,5; 50 x 1,5

AXLE:

plain steel \varnothing 6, \varnothing 8, \varnothing 10, \varnothing 12
 Design: internal thread, external thread, spring axle, rigid axle,
 axle with width across flats.
 optional: V2A-axle

EASY RUN BEARINGS:

Thermoplastic material with row of steel balls
 optional: corrosion-resistant construction

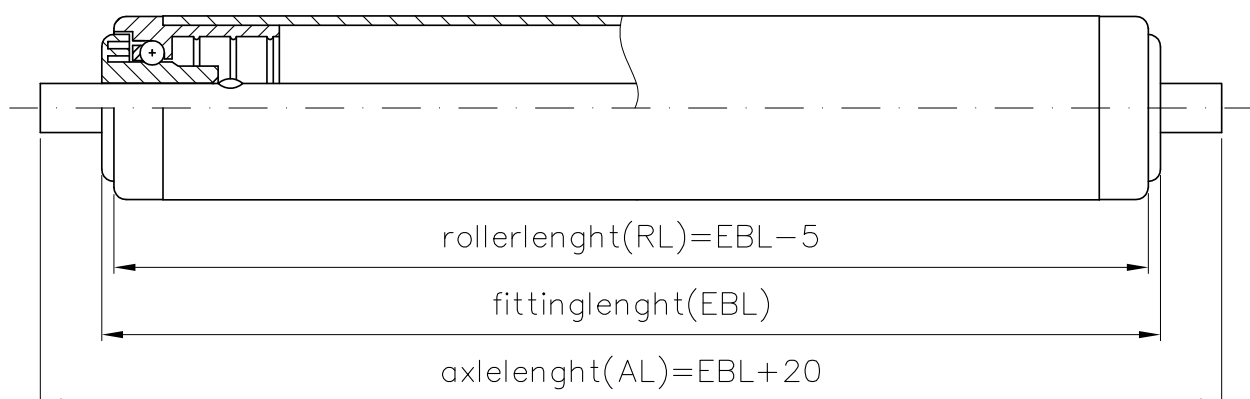

SERIES 2000 - CONSTRUCTION WITH EXTERNAL THREAD				
tube-ø (mm)	axle-ø (mm)	8	10	12
ø 30 ø 40 ø 50 ø 60	external thread:	M 8x25	M 10x25	M 12x25
	tubelenght =	EBL -22	EBL -24	EBL -27
	rollerlenght =	EBL -20	EBL -22	EBL -25
	axlelenght =	EBL +30		
ø 80	tubelenght =	EBL -26	EBL -28	EBL -31
	rollerlenght =	EBL -20	EBL -22	EBL -25
	axlelenght =	EBL +30		

SERIES 2000 - CONSTRUCTION WITH INTERNAL THREAD				
tube-ø (mm)	axle-ø (mm)	8	10	12
ø 30 ø 40 ø 50 ø 60	internal thread:	M 5x15	M 6x15	M 8x25
	tubelenght =	EBL -8		
	rollerlenght =	EBL -6		
	axlelenght =	EBL		
ø 80	tubelenght =	EBL -12		
	rollerlenght =	EBL -6		
	axlelenght =	EBL		

SERIES 2000 - CONSTRUCTION WITH SPRING AXLE					
tube-ø (mm)	axle-ø (mm)	8	10	12	SK11
ø 30 ø 40 ø 50 ø 60	tubelenght =	EBL -8			
	rollerlenght =	EBL -6			
	axlelenght =	EBL +20			
ø 80	tubelenght =	EBL -12			
	rollerlenght =	EBL -6			
	axlelenght =	EBL +20			

SERIES 2000 - CONSTR. WITH WIDTH ACROSS FLATS				
tube-ø (mm)	axle-ø (mm)	10	12	
ø 30 ø 40 ø 50 ø 60	width across flats	SW 8x10	SW 10x10	
	tubelenght =	EBL -8		
	rollerlenght =	EBL -6		
	axlelenght =	EBL +20		
ø 80	tubelenght =	EBL -12		
	rollerlenght =	EBL -6		
	axlelenght =	EBL +20		

SERIES 2000



ADVANTAGES:

- Cost-effective
- Free running
- Suitable for high- and low-temperature applications
- Bevelled roller ends for the lateral retention of conveyed material
- Anti-static carrying roller

APPLICATION:

- For in-plant conveyor systems
- Temperature-resistant from -30°C to + 60°C

MAX. DYNAMIC CARRYING CAPACITY:

- conveyor roller ø 30 – 0,40 kN
- conveyor roller ø 40 – 0,80 kN
- conveyor roller ø 50 – 1,10 kN
- conveyor roller ø 60 – 1,20 kN
- conveyor roller ø 80 – 1,50 kN

MAX. CONVEYOR SPEED

0,6 m/s for conveyor roller ø30, ø40
0,8 m/s for conveyor roller ø50, ø60 ø80

TUBE DIMENSIONS:

galvanized steel tube in accordance with DIN 2394
galvanized: ø30x1,5; ø40x1,5; ø50x1,5; ø60x1,5; ø80x2

AXLE:

plain steel ø 6, ø 8, ø 10, ø 12
Design: internal thread, external thread, spring axle, rigid axle, axle with width across flats.

EASY RUN BEARINGS:

Galvanized sheet steel with deep-drawn and hardened cup-and-cone bearings, lubricated

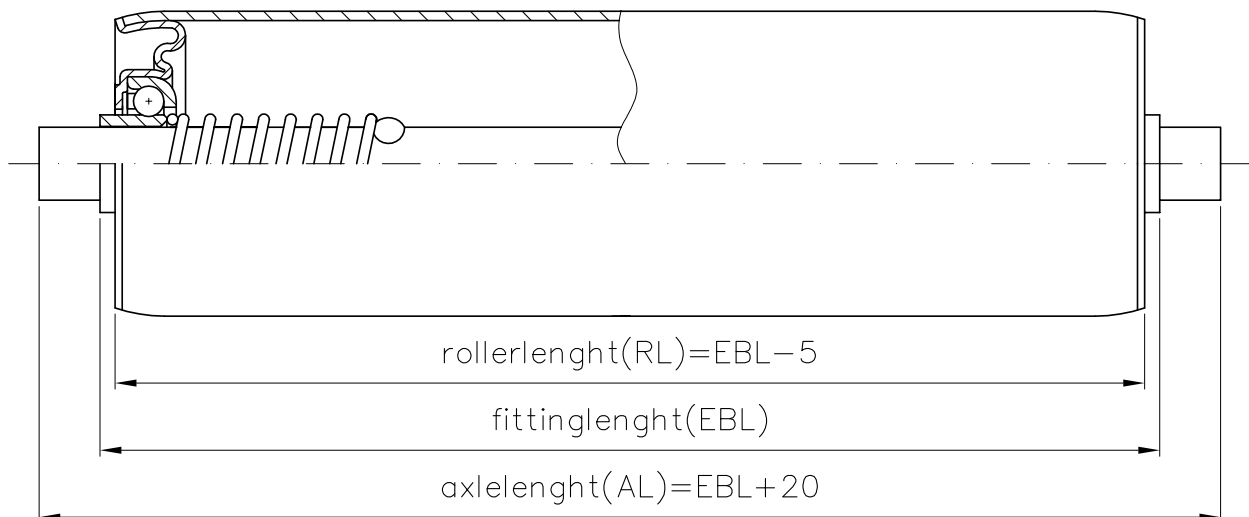



SERIES 2500

SERIES 2600

SERIES 2500 - CONSTRUCTION WITH EXTERNAL THREAD

tube- \varnothing (mm)	axle- \varnothing (mm)	10	12	14	15
\varnothing 40 \varnothing 50 \varnothing 60 \varnothing 80	external thread:	M 10x25	M 12x25	M 14x25	M 14x25
	tubelenght =	EBL -26	EBL -29	EBL -31	EBL -31
	rollerlenght =	EBL -22	EBL -25	EBL -27	EBL -27
	axlelenght =	EBL +30			

SERIES 2500 - CONSTRUCTION WITH INTERNAL THREAD

tube- \varnothing (mm)	axle- \varnothing (mm)	10	12	14	15
\varnothing 40 \varnothing 50 \varnothing 60 \varnothing 80	internal thread:	M 6x15	M 8x15	M 10x15	M 10x15
	tubelenght =	EBL -14			
	rollerlenght =	EBL -10			
	axlelenght =	EBL			

SERIES 2600 - CONSTRUCTION WITH EXTERNAL THREAD

tube- \varnothing (mm)	axle- \varnothing (mm)	20	25
\varnothing 63,5 \varnothing 80 \varnothing 89	external thread:	M 20x40	M 24x40
	tubelenght =	EBL -34	EBL -36
	rollerlenght =	EBL -28	EBL -30
	axlelenght =	EBL +50	

SERIES 2600 - CONSTRUCTION WITH INTERNAL THREAD

tube- \varnothing (mm)	axle- \varnothing (mm)	20	25
\varnothing 63,5 \varnothing 80 \varnothing 89	internal thread:	M 12x18	M 16x24
	tubelenght =	EBL -16	
	rollerlenght =	EBL -10	
	axlelenght =	EBL	

ADVANTAGES:

- Bevelled roller ends for the lateral retention of conveyed material
- Suitable for heavyweight loads
- Splash-proof and dust-proof sealed ball bearings
- Suitable for high speeds of rotation
- Anti-static carrying roller

APPLICATION:

- For in-plant conveyor systems
- For the conveyance of heavy goods, specifically pallets and containers
- Temperature-resistant from -30°C to + 80°C

MAX. DYNAMIC CARRYING CAPACITY:

- conveyor roller \varnothing 63 – 2,5 kN
- conveyor roller \varnothing 80 – 3,0 kN
- conveyor roller \varnothing 89 – 5,0 kN
- conveyor roller \varnothing 108 – 5,0 kN

MAX. DYNAMIC CARRYING CAPACITY:

1,4 m/s for conveyor roller \varnothing 40, \varnothing 50, \varnothing 60, \varnothing 80
 1,8 m/s for conveyor roller \varnothing 63, \varnothing 80, \varnothing 89, \varnothing 108

TUBE DIMENSIONS:

galvanized steel tube in accordance with DIN 2394
 galvanized: \varnothing 40 x 1,5; \varnothing 50 x 1,5; \varnothing 50 x 2; \varnothing 50 x 3; 60 x 1,5 \varnothing 60 x 2; \varnothing 60 x 3; \varnothing 80 x 2 bei Serie 2500
 galvanized: \varnothing 63 x 2,9; \varnothing 80 x 2; \varnothing 80 x 3; \varnothing 89 x 3; \varnothing 108 x 3,25 bei Serie 2600

AXLE:

plain steel \varnothing 8, \varnothing 10, \varnothing 12, \varnothing 14, \varnothing 15, \varnothing 17 at series 2500
 plain steel \varnothing 20, \varnothing 25 at series 2600

Design: internal thread, external thread, spring axle, rigid axle, axle with width across flats.

BEARINGS:

galvanized sheet steel with:
 precision ball bearings 6202-ZZ (-2RS) at series 2500
 precision ball bearings 6204-ZZ (-2RS) at series 2600

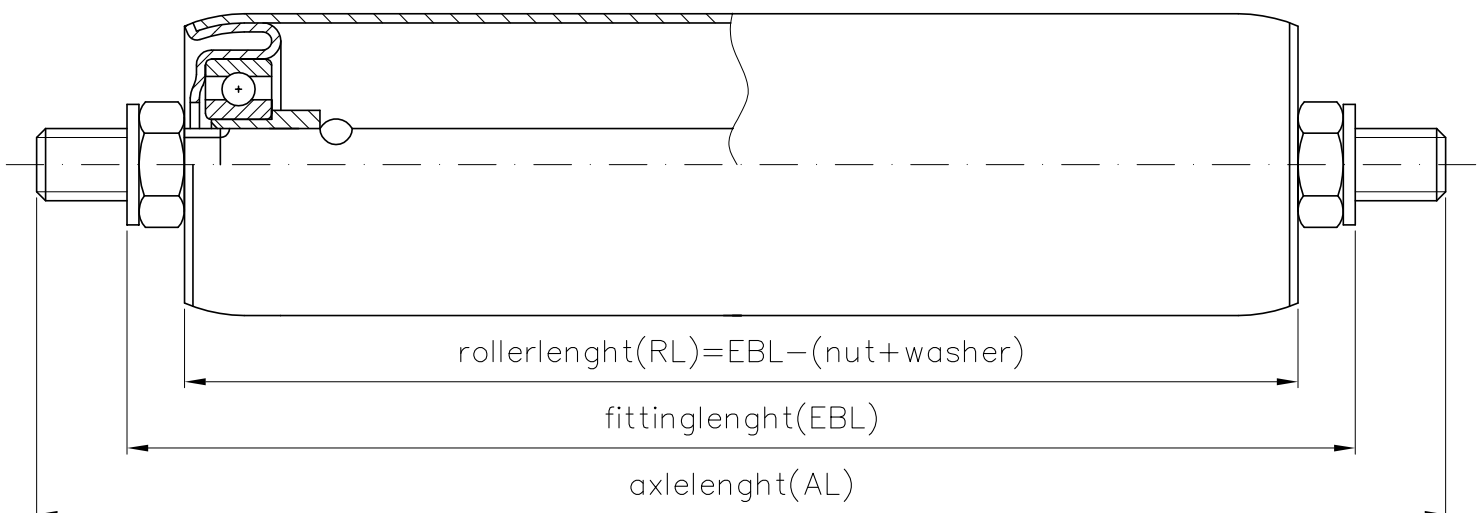



SERIES 3700

SERIES 3700 - CONSTRUCTION WITH EXTERNAL THREAD					
tube- \varnothing (mm)	axle- \varnothing (mm)	8	10	12	14
$\varnothing 50$	external thread:	M 8x15	M 10x15	M 12x15	M 14x20
	tubelenght =	EBL -29	EBL -31	EBL -34	EBL -36
	rollerlenght =	EBL -19	EBL -21	EBL -24	EBL -26
	axlelenght =	EBL +30			

SERIES 3700 - CONSTRUCTION WITH INTERNAL THREAD					
Rohr- \varnothing (mm)	axle- \varnothing (mm)	8	10	12	14
$\varnothing 50$	internal thread:	M 5x15	M 6x15	M 8x15	M 10x15
	tubelenght =	EBL -18,5			
	rollerlenght =	EBL -8,5			
	axlelenght =	EBL			

SERIES 3700 - CONSTRUCTION WITH SPRING AXLE					
tube- \varnothing (mm)	axle- \varnothing (mm)	8	10	12	SK 11
$\varnothing 50$	tubelenght =	EBL -18,5			
	rollerlenght =	EBL -8,5			
	axlelenght =	EBL +20			

SERIES 3700 - CONSTR. WITH WIDTH ACROSS FLATS					
tube- \varnothing (mm)	axle- \varnothing (mm)	8	10	12	14
$\varnothing 50$	width across flats	SW 6x10	SW 8x10	SW 10x10	SW 12x10
	tubelenght =	EBL -18,5			
	rollerlenght =	EBL -8,5			
	axlelenght =	EBL +20			

ADVANTAGES:

- Guaranteed electroconductive (contact resistance $< 1000 \text{ k}\Omega$)
- Completely maintenance-free and servicing-free with the use of precision deep-groove ball bearings of 6202-series (optional ZZ or 2RS-seal)
- Simple lateral shifting of containers thanks to conical form at the end of carrier roller
- Additional labyrinth seal offers protection from water spray and coarse dust
- High quality manufacturing with individual design options for bearing shield

APPLICATION:

- For in-plant conveyor systems
- Temperature-resistant from -10°C to $+40^\circ\text{C}$

MAX. DYNAMIC CARRYING CAPACITY:

- conveyor roller $\varnothing 50 - 3 \text{ kN}$

MAX. CONVEYOR SPEED

2,0 m/s for conveyor roller $\varnothing 50$

TUBE DIMENSIONS:

galvanized steel tube in accordance with DIN 2394
dimension $\varnothing 50 \times 1.5 \text{ mm}$
optional: V2A-tube $\varnothing 50 \times 1,5$

AXLE:

plain steel $\varnothing 8, \varnothing 10, \varnothing 12, \varnothing 14, \text{SK11}$
Design: internal thread, external thread, spring axle, rigid axle, axle with width across flats. Optional

BEARINGS:

Synthetic bearing plate with precision deep groove ball bearings 6202-ZZ (-2RS) and labyrinth seal

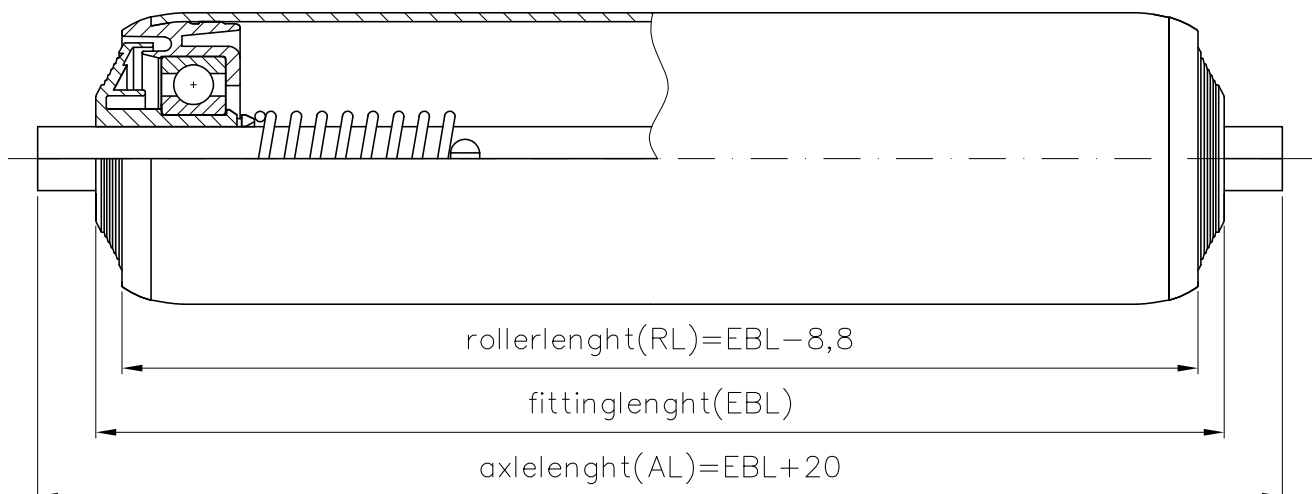



kraus
Eine Idee voraus

DRIVEN ROLLERS





SERIES 3760

SERIES 3760 - CONSTRUCTION WITH EXTERNAL THREAD					
tube- \varnothing (mm)	axle- \varnothing (mm)	8	10	12	14
$\varnothing 50$	external thread:	M 8x15	M 10x15	M 12x15	M 14x20
	tubelenght =	EBL -29	EBL -31	EBL -34	EBL -36
	rollerlenght =	EBL -19	EBL -21	EBL -24	EBL -26
	axlelenght =	EBL +30			EBL +40

SERIES 3760 - CONSTRUCTION WITH INTERNAL THREAD					
tube- \varnothing (mm)	axle- \varnothing (mm)	8	10	12	14
$\varnothing 50$	internal thread:	M 5x15	M 6x15	M 8x15	M 10x15
	tubelenght =	EBL -18,5			
	rollerlenght =	EBL -18,5			
	axlelenght =	EBL			

SERIES 3760 - CONSTRUCTION WITH SPRING AXLE					
tube- \varnothing (mm)	Achs- \varnothing (mm)	8	10	12	SK 11
$\varnothing 50$	tubelenght =	EBL -18,5			
	rollerlenght =	EBL -8,5			
	axlelenght =	EBL +20			

SERIES 3760 - CONSTR. WITH WIDTH ACROSS FLATS					
tube- \varnothing (mm)	axle- \varnothing (mm)	8	10	12	14
$\varnothing 50$	width across flats	SW 6x10	SW 8x10	SW 10x10	SW 12x10
	tubelenght =	EBL -18,5			
	rollerlenght =	EBL -8,5			
	axlelenght =	EBL +20			

ADVANTAGES:

- Guaranteed electroconductive (contact resistance < 1000 k Ω)
- Completely maintenance-free and servicing-free with the use of precision deep-groove ball bearings of 6202-series (optional ZZ or 2RS-seal)
- Simple lateral shifting of containers thanks to conical form at the end of carrier roller
- Additional labyrinth seal offers protection from water spray and coarse dust
- High quality manufacturing with individual design options for bearing shield

APPLICATION:

- For in-plant conveyor systems
- Temperature-resistant from -10°C to + 40°C

MAX. DYNAMIC CARRYING CAPACITY:

- conveyor roller $\varnothing 50 - 3$ kN
- Tractive capacity for round belt up to a loading of 0.3 kN standard size for the grooves: A = 40, B = 30 for round belt $\varnothing 5$ mm

MAX. CONVEYOR SPEED

2,0 m/s for conveyor roller $\varnothing 50$

TUBE DIMENSIONS:

galvanized steel tube in accordance with DIN 2394 dimension $\varnothing 50 \times 1.5$ mm
optional: V2A-tube $\varnothing 50 \times 1,5$

AXLE:

plain steel $\varnothing 8, \varnothing 10, \varnothing 12, \varnothing 14, SK11$
Design: internal thread, external thread, spring axle, rigid axle, axle with width across flats. Optional V2A-axle

BEARINGS:

Synthetic bearing plate with precision deep groove ball bearings 6202-ZZ (-2RS) and labyrinth seal

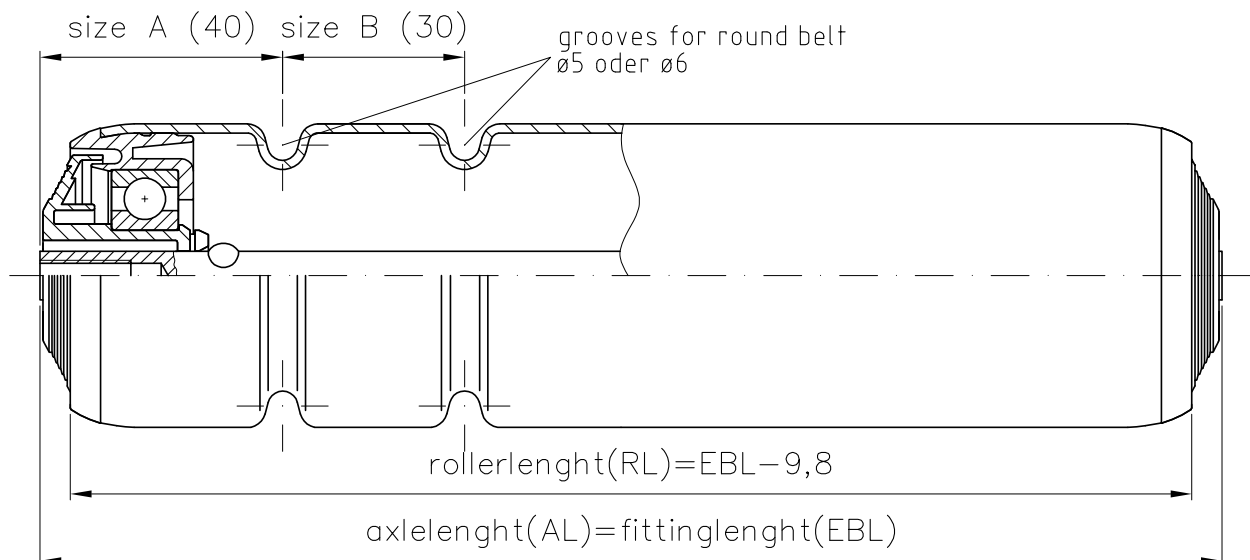



SERIES 4830

SERIES 5170

SERIES 4830 - CONSTRUCTION WITH EXTERNAL THREAD					
tube- \varnothing (mm)	axle- \varnothing (mm)	12	14	15	17
\varnothing 50 \varnothing 60 \varnothing 80	external thread:	M 12x25	M 14x25	M 14x25	M 16x25
	tubelenght =	EBL -74	EBL -76	EBL -76	EBL -78
	rollerlenght =	EBL -64	EBL -66	EBL -66	EBL -68
	axlelenght =	EBL +30			EBL +40

SERIES 4830 - CONSTRUCTION WITH INTERNAL THREAD					
tube- \varnothing (mm)	axle- \varnothing (mm)	12	14	15	17
\varnothing 50 \varnothing 60 \varnothing 80	internal thread:	M 8x15	M 10x15	M 10x15	M 12x18
	tubelenght =	EBL -55			
	rollerlenght =	EBL -45			
	axlelenght =	EBL			

ADVANTAGES:

- quiet operation
- maintenance-free
- Anti-static carrying roller
- customized solutions

APPLICATION:

- For in-plant conveyor systems, series 4830
- For the conveyance of heavy goods, specifically pallets and containers, series 5170
- Temperature-resistant from -10°C to + 40°C

MAX. DYNAMIC CARRYING CAPACITY:

- conveyor roller \varnothing 50 - 0,8 kN
- conveyor roller \varnothing 60 - 1,0 kN
- conveyor roller \varnothing 80 - 2,5 kN
- conveyor roller \varnothing 89 - 5,0 kN

TUBE DIMENSIONS:

- galvanized steel tube in accordance with DIN 2394
- dimensions: \varnothing 50 x 1,5; \varnothing 50 x 2; \varnothing 60 x 1,5; \varnothing 60 x 2; \varnothing 80 x 2; \varnothing 80 x 3; \varnothing 89 x 2,9; \varnothing 89 x 5, \varnothing 108 x 3,25
- PVC-tube: \varnothing 50 x 2,8; \varnothing 63 x 3
- V2A-tube: \varnothing 50 x 1,5; \varnothing 60,3 x 1,6; \varnothing 80 x 2

AXLE:

- plain steel: \varnothing 8; \varnothing 10; \varnothing 12; \varnothing 14; \varnothing 15; \varnothing 17; \varnothing 20; \varnothing 25
- Design: internal thread, external thread, spring axle, rigid axle, axle with width across flats. Optional V2A-axle

BEARINGS:

- precision ball bearings 6202-ZZ (-2RS) at series 2500
- precision ball bearings 6204-ZZ (-2RS) at series 2600

DRIVE:

- Series 4830 toothed belt pulley HTD-8M z = 20 PVC
- other toothed belt pulleys for pallet transport customized solutions

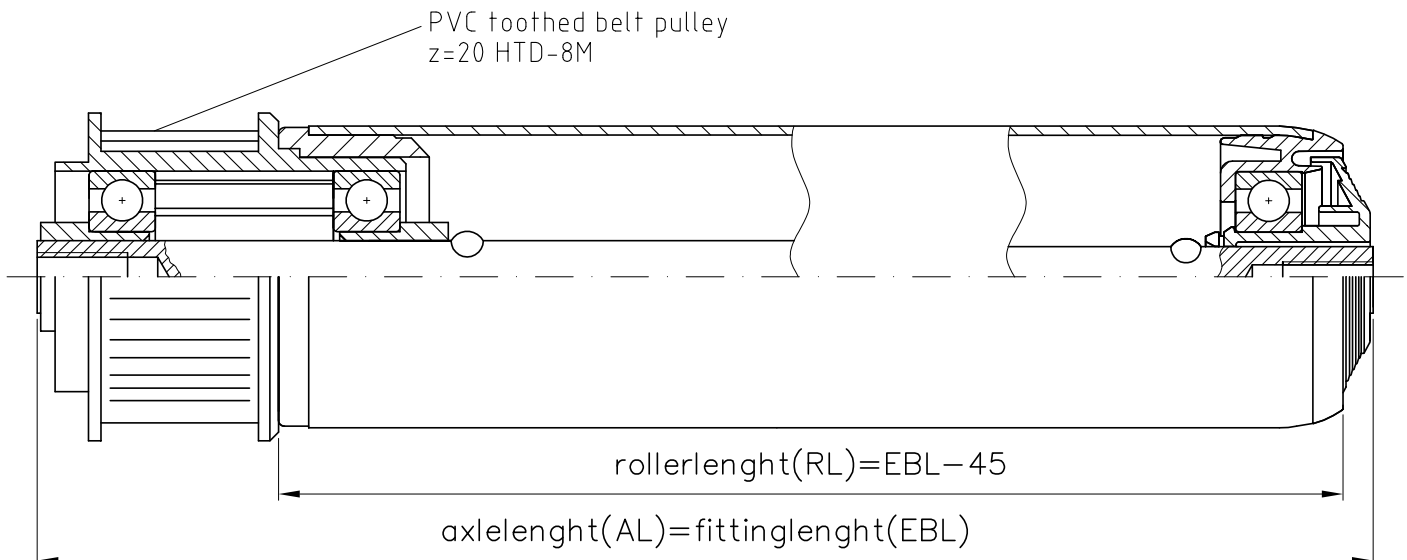



SERIES 4840

SERIES 4840 - CONSTRUCTION WITH EXTERNAL THREAD					
tube- ϕ (mm)	axle- ϕ (mm)	8	10	12	14
ϕ 50 ϕ 60	external thread:	M 8x15	M 10x15	M 12x15	M 14x20
	tubelenght =	EBL -65	EBL -67	EBL -70	EBL -72
	rollerlenght =	RL -55	RL -57	RL -60	RL -62
	axlelenght =	EBL +30			EBL +40

SERIES 4840 - CONSTRUCTION WITH INTERNAL THREAD					
tube- ϕ (mm)	axle- ϕ (mm)	8	10	12	14
ϕ 50 ϕ 60	internal thread:	M 5x15	M 6x15	M 8x15	M 10x15
	tubelenght =	EBL -51			
	rollerlenght =	RL -41			
	axlelenght =	EBL			

SERIES 4840 - CONSTRUCTION WITH SPRING AXLE					
tube- ϕ (mm)	axle- ϕ (mm)	8	10	12	14
ϕ 50 ϕ 60	tubelenght =	EBL -51			
	rollerlenght =	RL -41			
	axlelenght =	EBL +20			

SERIES 4840 - CONSTR. WITH WIDTH ACROSS FLATS					
tube- ϕ (mm)	axle- ϕ (mm)	8	10	12	14
ϕ 50 ϕ 60	width across flats	SW 6x10	SV 8x10	SV 10x10	SW 12x10
	tubelenght =	EBL -51			
	rollerlenght =	RL -41			
	axlelenght =	EBL +20			

ADVANTAGES:

- High power transmission, efficiency factor of 98%
- With one engine can be driven up to 50 rollers
- By the 9 ribs you have belt variants from 2 – 4 ribs
- Designed for curved conveyor lines
- Guaranteed electroconductive (contact resistance < 1000 k Ω)
- Completely maintenance-free and servicing-free with the use of precision deep-groove ball bearings of 6202-series (optional ZZ or 2RS-seal)
- Useable for friction move
- Simple lateral shifting of containers thanks to conical form at the end of carrier roller
- Additional labyrinth seal offers protection from water spray and coarse dust
- Minimum operational noise thanks to plastic roller belt, DIN-deep grooved precision ball bearings and Multi-W belt

APPLICATION:

- For in-plant conveyor systems
 - Temperature-resistant from -10°C to + 40°C
- Max. dynamic carrying capacity:
conveyor roller ϕ 50 – 0,8 kN
conveyor roller ϕ 60 – 1,0 kN

MAX. CONVEYOR SPEED

2,0 m/s for conveyor roller ϕ 50

TUBE DIMENSIONS:

- galvanized steel tube in accordance with DIN 2394 dimensions: ϕ 50 x 1,5; ϕ 50 x 2; ϕ 60 x 1,5; ϕ 60 x 2
- PVC-tube: ϕ 50 x 2,8; ϕ 63 x 3
- V2A -tube: ϕ 50 x 1,5; ϕ 60,3 x 1,6

AXLE:

plain steel ϕ 8, ϕ 10, ϕ 12, ϕ 14, SK11
Design: internal thread, external thread, spring axle, rigid axle, axle with width across flats. Optional V2A-axle

BEARINGS:

Synthetic bearing plate with precision deep groove ball bearings 3x 6202-ZZ (-2RS) and labyrinth seal

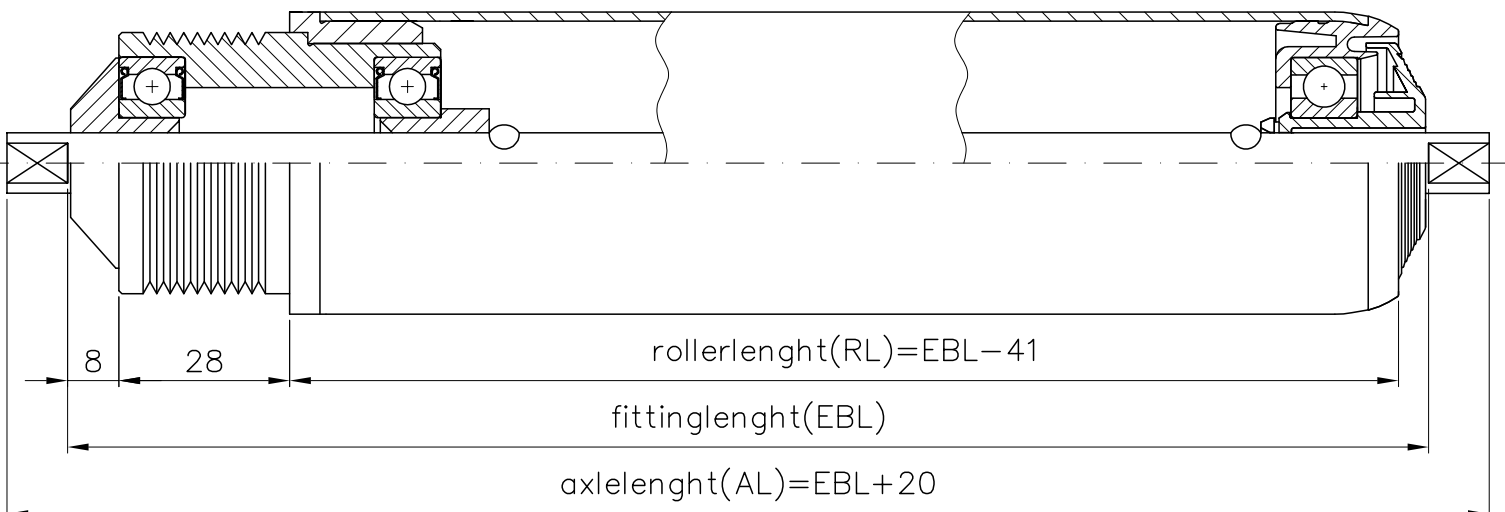



SERIES 4900

Accumulation or stowing rollers are used where piece goods up to 100 kg must be transported and stopped. The cost-effective accumulation roller conveyors can be stopped at any time with a single, permanently running drive. An accumulator bush is located between the roller shell and the drive element. While in accumulation or stowing operating mode, the drive element is able to rotate although the roller shell is blocked with the stopped material to be conveyed. The driving of the roller shell is carried out by means of friction and capillary action.

ADVANTAGES:

- adjustable friction move
- Anti-static carrying roller
- many possible combinations

APPLICATION:

- For in-plant conveyor systems
- Temperature-resistant from -10°C to + 40°C

MAX. DYNAMIC CARRYING CAPACITY:

- conveyor roller \varnothing 50 – 0,8 kN
- conveyor roller \varnothing 60 – 1,0 kN

TUBE DIMENSIONS:

- galvanized steel tube in accordance with DIN 2394 dimensions: \varnothing 50 x 1,5; \varnothing 50 x 2; \varnothing 60 x 1,5; \varnothing 60 x 2
- PVC-tube: \varnothing 50 x 2,8; \varnothing 63 x 3
- V2A -tube: \varnothing 50 x 1,5; \varnothing 60,3 x 1,6

DRIVE:

- double chain wheel $\frac{1}{2}$ " x 5/16" z = 14 steel or PVC
- double chain wheel $\frac{1}{2}$ " x 5/16" z = 11 steel or PVC
- single chain wheel $\frac{1}{2}$ " x 5/16" z = 14 steel or PVC
- single chain wheel $\frac{1}{2}$ " x 5/16" z = 11 steel or PVC
- toothed belt pulley HTD-8M z = 20 PVC
- Multi W head 9 ribs
- customized $\frac{1}{2}$ " chain wheels

BEARINGS

precision ball bearings 6202-ZZ (-2RS) at series 2500

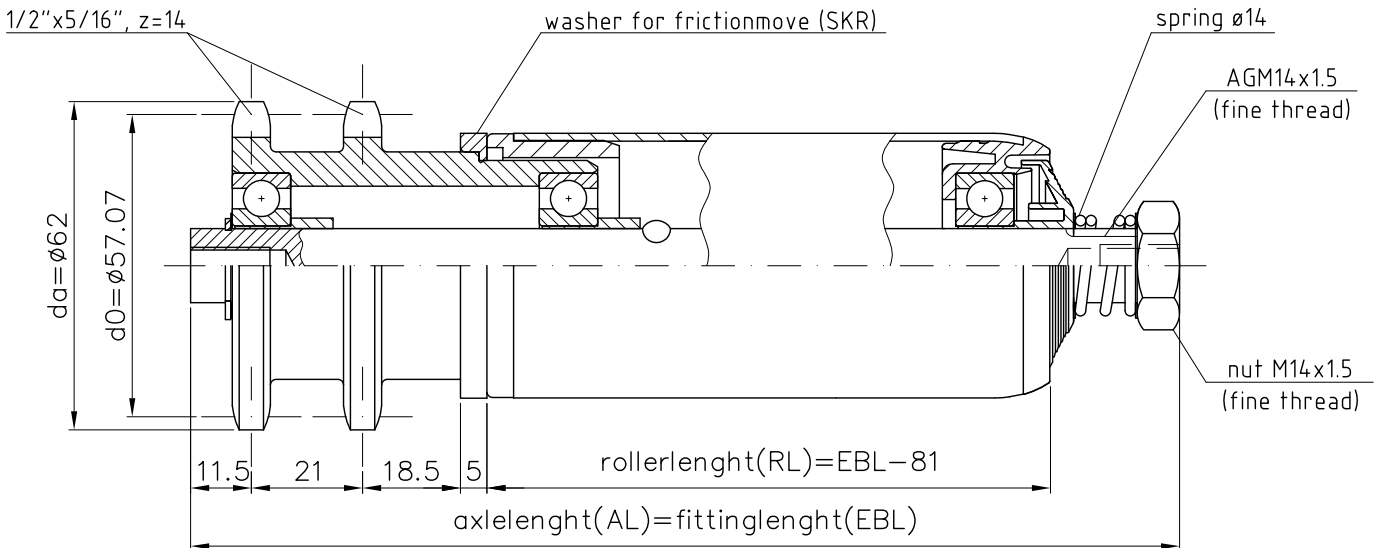



SERIES 4550 SERIES 5070

SERIES 4550/5070 - CONSTR. WITH EXTERNAL THREAD					
tube- \varnothing (mm)	axle- \varnothing (mm)	12	14	15	17
\varnothing 50 \varnothing 60 \varnothing 80	internal thread:	M 12x25	M 14x25	M 14x25	M 16x25
	tubelenght =	EBL -62	EBL -64	EBL -64	EBL -66
	rollerlenght =	EBL -52	EBL -54	EBL -54	EBL -56
	axlelenght =	EBL +30			EBL +40

SERIES 4550/5070 - CONSTR. WITH INTERNAL THREAD					
tube- \varnothing (mm)	axle- \varnothing (mm)	12	14	15	17
\varnothing 50 \varnothing 60 \varnothing 80	internal thread:	M 8x15	M 10x15	M 10x15	M 12x18
	tubelenght =	EBL -43			
	rollerlenght =	EBL -33			
	axlelenght =	EBL			

ADVANTAGES:

- Cost-effective
- Anti-static carrying roller
- chain wheel welded to tube

APPLICATION:

- For in-plant conveyor systems
- Temperature-resistant from -10°C to + 40°C

MAX. DYNAMIC CARRYING CAPACITY:

- conveyor roller \varnothing 50 – 0,8 kN
- conveyor roller \varnothing 60 – 1,0 kN
- conveyor roller \varnothing 80 – 1,2 kN

MAX. CONVEYOR SPEED

0,5 m/s for conveyor roller \varnothing 50, \varnothing 60, \varnothing 80

TUBE DIMENSIONS:

- batch-galvanized steel tube in accordance with DIN 2394 dimensions: \varnothing 50 x 1,5; \varnothing 50 x 2; \varnothing 60 x 1,5; \varnothing 60 x 2; \varnothing 80 x 2

AXLE:

plain steel \varnothing 10, \varnothing 12, \varnothing 14, \varnothing 15, \varnothing 17
Design: internal thread, external thread, rigid axle, axle with width across flats. Optional V2A-axle

DRIVE:

Series 4550: 1/2" x 5/16" number of teeth = 11 steel
Series 5070: 1/2" x 5/16" number of teeth = 11 steel

BEARINGS:

precision ball bearings 6202-ZZ (-2RS)
non driven side: Series 3700 or Series 2500

OPTIONAL:

PVC- chain wheel pressed for friction- or fixed move

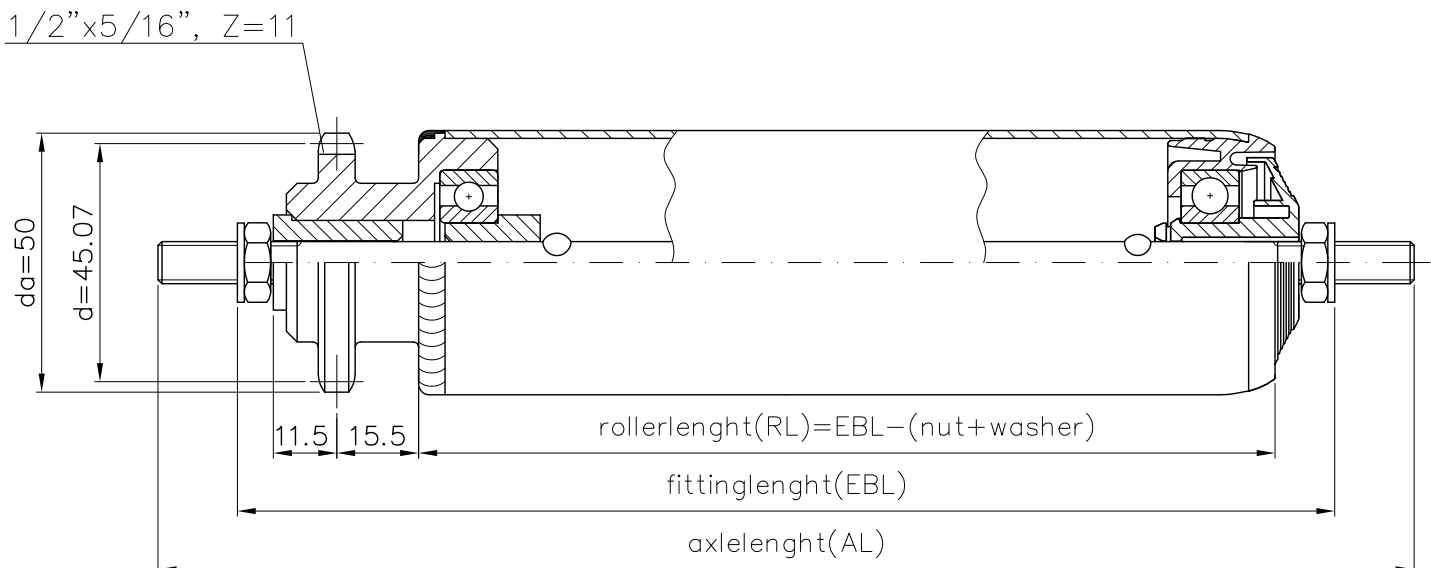



SERIES 5020

SERIES 5020 - CONSTRUCTION WITH EXTERNAL THREAD					
tube- \varnothing (mm)	axle- \varnothing (mm)	12	14	15	17
\varnothing 50 \varnothing 60 \varnothing 80	external thread:	M 12x25	M 14x25	M 14x25	M 16x25
	tubelenght =	EBL -86	EBL -88	EBL -88	EBL -90
	rollerlenght =	EBL -76	EBL -78	EBL -78	EBL -80
	axlelenght =	EBL +30			EBL +40

SERIES 5020 - CONSTRUCTION WITH INTERNAL THREAD					
tube- \varnothing (mm)	axle- \varnothing (mm)	12	14	15	17
\varnothing 50 \varnothing 60 \varnothing 80	internal thread:	M 8x15	M 10x15	M 10x15	M 12x18
	tubelenght =	EBL -67			
	rollerlenght =	EBL -57			
	axlelenght =	EBL			

ADVANTAGES:

- Cost-effective
- Anti-static carrying roller
- chain wheel welded to tube

APPLICATION:

- For in-plant conveyor systems
- Temperature-resistant from -10°C to + 40°C

MAX. DYNAMIC CARRYING CAPACITY:

- conveyor roller \varnothing 50 – 0,8 kN
- conveyor roller \varnothing 60 – 1,0 kN
- conveyor roller \varnothing 80 – 1,2 kN

MAX. CONVEYOR SPEED

0,5 m/s for conveyor roller \varnothing 50, \varnothing 60, \varnothing 80

TUBE DIMENSIONS:

- batch-galvanized steel tube in accordance with DIN 2394 dimensions: \varnothing 50 x 1,5; \varnothing 50 x 2; \varnothing 60 x 1,5; \varnothing 60 x 2; \varnothing 80 x 2

AXLE:

plain steel \varnothing 10, \varnothing 12, \varnothing 14, \varnothing 15, \varnothing 17
Design: internal thread, external thread, rigid axle, axle with width across flats. Optional V2A-axle

DRIVE:

Series 5020: 1/2" x 5/16" number of teeth = 14 steel

BEARINGS:

precision ball bearings 6202-ZZ (-2RS)
non driven side: Series 3700 or Series 2500

OPTIONAL:

double chain wheel 1/2" x 5/16" number of teeth = 11 steel
PVC- chain wheel pressed for friction- or fixed move

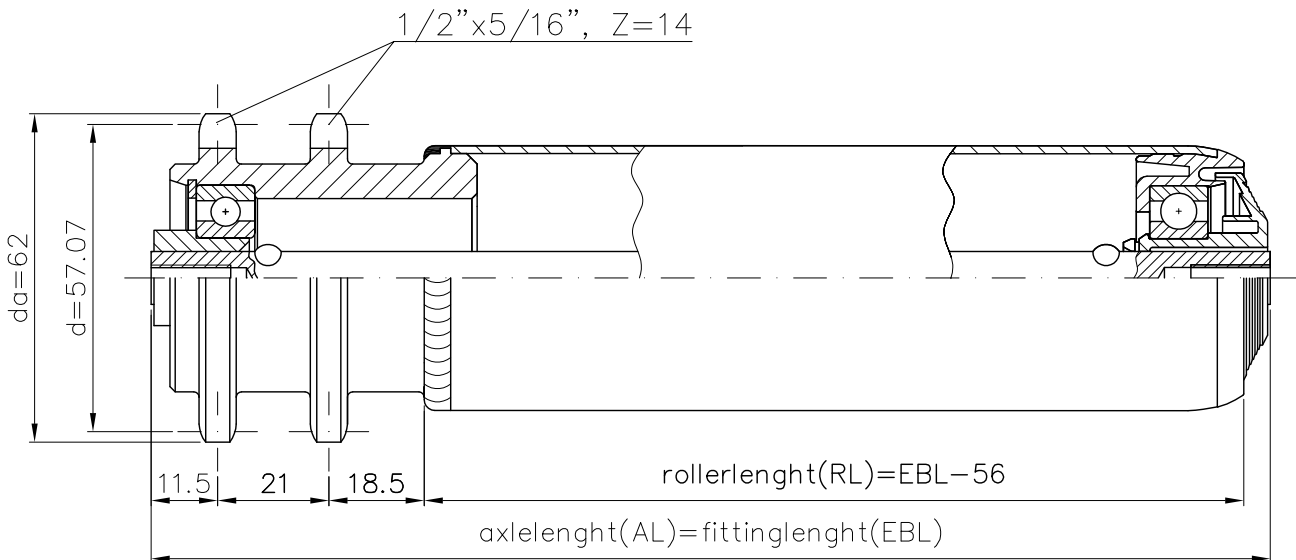



SERIES 5103, 5104, 5105

SERIES 5103, 5104, 5105 - CONSTRUCTION WITH EXTERNAL THREAD			
tube- \varnothing (mm)	axle- \varnothing (mm)	20	25
\varnothing 80 \varnothing 89 \varnothing 108	external thread:	M 20x40	M 24x40
	tubelenght =	EBL -84	EBL -86
	rollerlenght =	EBL -76	EBL -78
	axlelenght =	EBL +50	

SERIES 5103, 5104, 5105 - CONSTRUCTION WITH INTERNAL THREAD			
tube- \varnothing (mm)	axle- \varnothing (mm)	20	25
\varnothing 80 \varnothing 89 \varnothing 108	internal thread:	M 10x15	M 16x24
	tubelenght =	EBL -75	
	rollerlenght =	EBL -67	
	axlelenght =	EBL	

SERIES 5103, 5104, 5105 - CONSTR. WITH WIDTH ACROSS FLATS			
tube- \varnothing (mm)	axle- \varnothing (mm)	20	25
\varnothing 80 \varnothing 89 \varnothing 108	width across flats	SW 14x10	SW 20x10
	tubelenght =	EBL -75	
	rollerlenght =	EBL -67	
	axlelenght =	EBL +20	

ADVANTAGES:

- strong construction
- chain wheel welded to tube

APPLICATION:

- For in-plant conveyor systems
- For the conveyance of heavy goods, specifically pallets and containers
- Temperature-resistant from -30°C to + 80°C
- for heavy duty

MAX. DYNAMIC CARRYING CAPACITY:

- conveyor roller \varnothing 80 – 2,5 kN
- conveyor roller \varnothing 89 – 3,5 kN
- conveyor roller \varnothing 89 x 5 – 5,0 kN
- conveyor roller \varnothing 108 – 5,0 kN

MAX. CONVEYOR SPEED

0,8 m/s for conveyor roller \varnothing 80, \varnothing 89, \varnothing 108

TUBE DIMENSIONS:

• batch-galvanized steel tube in accordance with DIN 2394
 dimensions: \varnothing 80 x 2; \varnothing 80 x 3; \varnothing 89 x 3; \varnothing 89 x 5; \varnothing 108 x 3,25; \varnothing 133 x 3,6; \varnothing 159 x 4,5

AXLE:

plain steel \varnothing 20; \varnothing 25, Design: internal thread, external thread, rigid axle, axle with width across flats

DRIVE:

double chain wheel:
 Series 5103: 5/8" x 3/8" number of teeth = 13 steel, d=66,3 da=73
 Series 5104: 5/8" x 3/8" number of teeth = 14 steel, d=71,3 da=78
 Series 5105: 5/8" x 3/8" number of teeth = 15 steel, d=76,3 da=83

BEARINGS:

precision ball bearings 6204-ZZ (-2RS) or 6005-ZZ (-2RS)
 non driven side: Series 2600

OPTION:

non driven side: Series 4100, non driven side: according tube dimension \varnothing 89 x5 massive turn part Series 4020

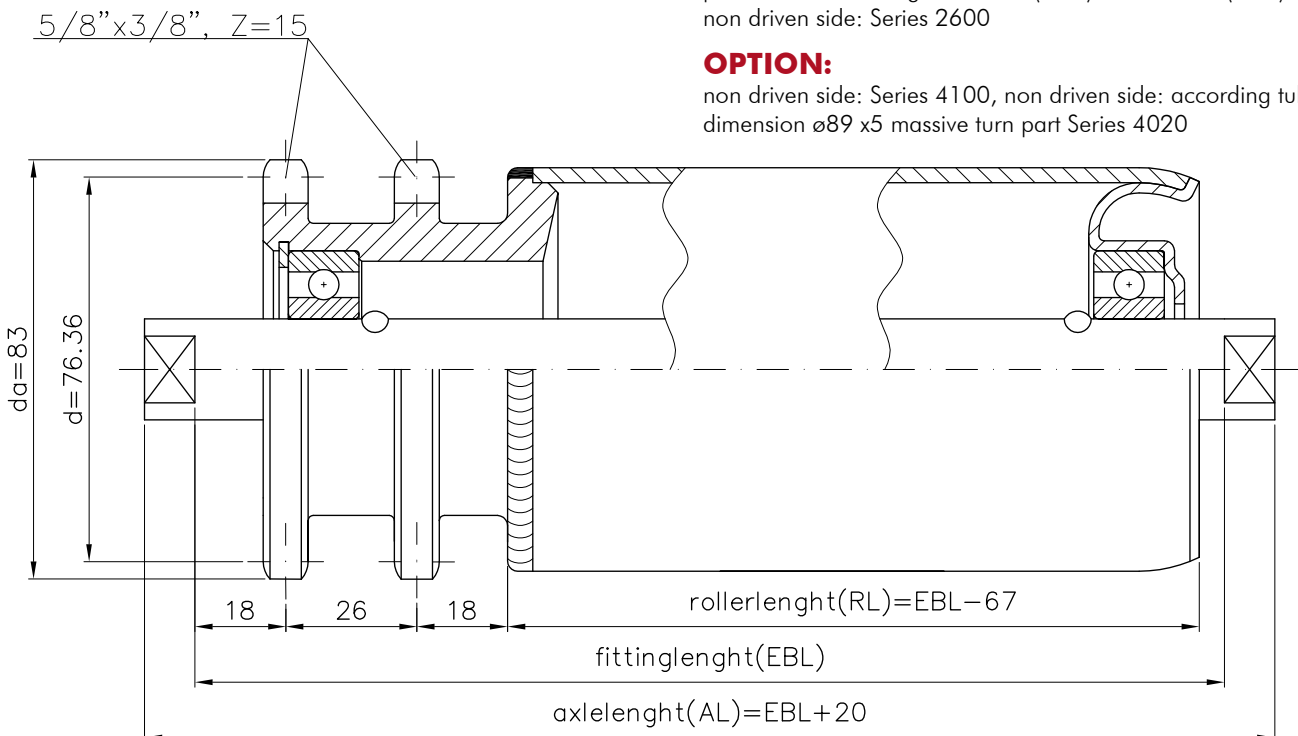



SERIES 5113 SERIES 5115

SERIES 5113, 5115 - CONSTR. WITH EXTERNAL THREAD			
tube-ø (mm)	axle-ø (mm)	20	25
ø 80 ø 89 ø 108	external thread:	M 20x40	M 24x40
	tubelenght =	EBL -58	EBL -59
	rollerlenght =	EBL -50	EBL -51
	axlelenght =	EBL +50	

SERIES 5113, 5115 - CONSTR. WITH INTERNAL THREAD			
tube-ø (mm)	axle-ø (mm)	20	25
ø 80 ø 89 ø 108	internal thread:	M 10x15	M 16x24
	tubelenght =	EBL -49	
	rollerlenght =	EBL -41	
	axlelenght =	EBL	

SERIES 5113, 5115 - CONSTR. WITH WIDTH ACROSS FLATS			
tube-ø (mm)	axle-ø (mm)	20	25
ø 80 ø 89 ø 108	width across flats	SW 14x10	SW 20x10
	tubelenght =	EBL -49	
	rollerlenght =	EBL -41	
	axlelenght =	EBL +20	

ADVANTAGES:

- strong construction
- chain wheel welded to tube

APPLICATION:

- For in-plant conveyor systems
- For the conveyance of heavy goods, specifically pallets and containers
- Temperature-resistant from -30°C to + 80°C
- for heavy duty

MAX. DYNAMIC CARRYING CAPACITY:

- conveyor roller ø 80 – 2,5 kN
- conveyor roller ø 89 – 3,5 kN
- conveyor roller ø 89 x 5 – 5,0 kN
- conveyor roller ø108 – 5,0 kN

MAX. CONVEYOR SPEED

0,8 m/s for conveyor roller ø80, ø89, ø108

TUBE DIMENSIONS:

• batch-galvanized steel tube in accordance with DIN 2394
 dimensions: ø80 x 2; ø 80 x 3; ø 89 x 3; ø89 x 5; ø 108 x 3,25;
 ø133 x 3,6; ø159 x 4,5

AXLE:

plain steel ø20; ø25, design: internal thread, external thread, rigid axle, axle with width across flats

DRIVE:

single chain wheel:

Series 5113: 5/8" x 3/8" number of teeth = 13 steel, d=66,3 da=73

Series 5115: 5/8" x 3/8" number of teeth = 15 steel, d=76,3 da=83

BEARINGS:

precision ball bearings 6204-ZZ (-2RS) or 6005-ZZ (-2RS)

non driven side: Series 2600

OPTION:

non driven side: Series 4100, non driven side: according tube dimension ø89 x5 massive turn part Series 4020

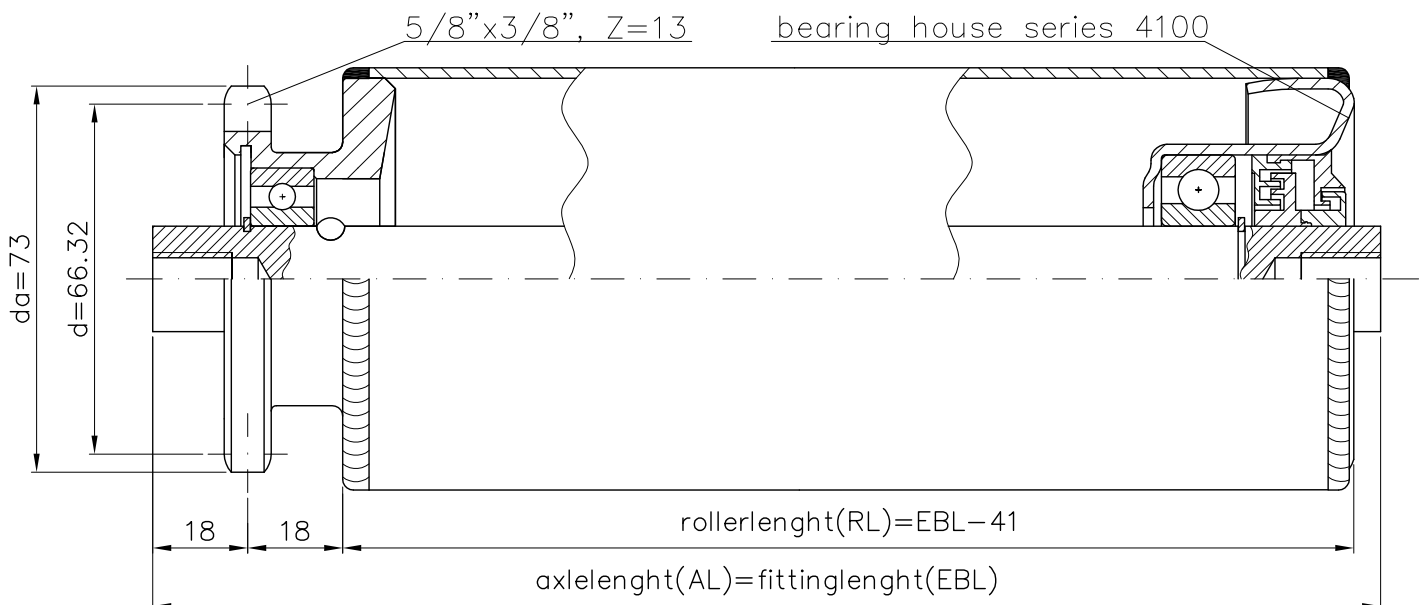



SERIES 5123

SERIES 5125

SERIES 5123, 5125 - CONSTR. WITH EXTERNAL THREAD			
tube-ø (mm)	axle-ø (mm)	20	25
ø 80 ø 89 ø 108	external thread:	M 20x40	M 24x40
	tubelenght =	EBL -92	EBL -94
	rollerlenght =	EBL -84	EBL -86
	axlelenght =	EBL +50	

SERIES 5123, 5125 - CONSTR. WITH INTERNAL THREAD			
tube-ø (mm)	axle-ø (mm)	20	25
ø 80 ø 89 ø 108	internal thread:	M 10x15	M 16x24
	tubelenght =	EBL -79	
	rollerlenght =	EBL -71	
	axlelenght =	EBL	

SERIES 5123, 5125 - CONSTR. WITH WIDTH ACROSS FLATS			
tube-ø (mm)	axle-ø (mm)	20	25
ø 80 ø 89 ø 108	width across flats	SW 14x10	SW 20x10
	tubelenght =	EBL -79	
	rollerlenght =	EBL -71	
	axlelenght =	EBL +20	

ADVANTAGES:

- strong construction
- chain wheel welded to tube

APPLICATION:

- For in-plant conveyor systems
- For the conveyance of heavy goods, specifically pallets and containers
- Temperature-resistant from -30°C to + 80°C
- for heavy duty

MAX. DYNAMIC CARRYING CAPACITY:

- conveyor roller ø 80 – 2,5 kN
- conveyor roller ø 89 – 3,5 kN
- conveyor roller ø 89 x 5 – 5,0 kN
- conveyor roller ø108 – 5,0 kN

MAX. CONVEYOR SPEED

0,8 m/s for conveyor roller ø80, ø89, ø108

TUBE DIMENSIONS:

• batch-galvanized steel tube in accordance with DIN 2394 dimensions: ø80 x 2; ø 80 x 3; ø 89 x 3; ø89 x 5; ø 108 x 3,25; ø133 x 3,6; ø159 x 4,5

AXLE:

plain steel ø20; ø25

Design: internal thread, external thread, rigid axle, axle with width across flats

DRIVE:

double chain wheel: Series 5123: 5/8" x 3/8" number of teeth = 13 steel, d=79,6 da=87

Series 5115: 5/8" x 3/8" number of teeth = 15 steel, d=91,6 da=100

BEARINGS:

precision ball bearings 6204-ZZ (-2RS) or 6005-ZZ (-2RS)
non driven side: Series 2600

OPTION:

non driven side: Series 4100, non driven side: according tube dimension ø89 x5 massive turn part Series 4020

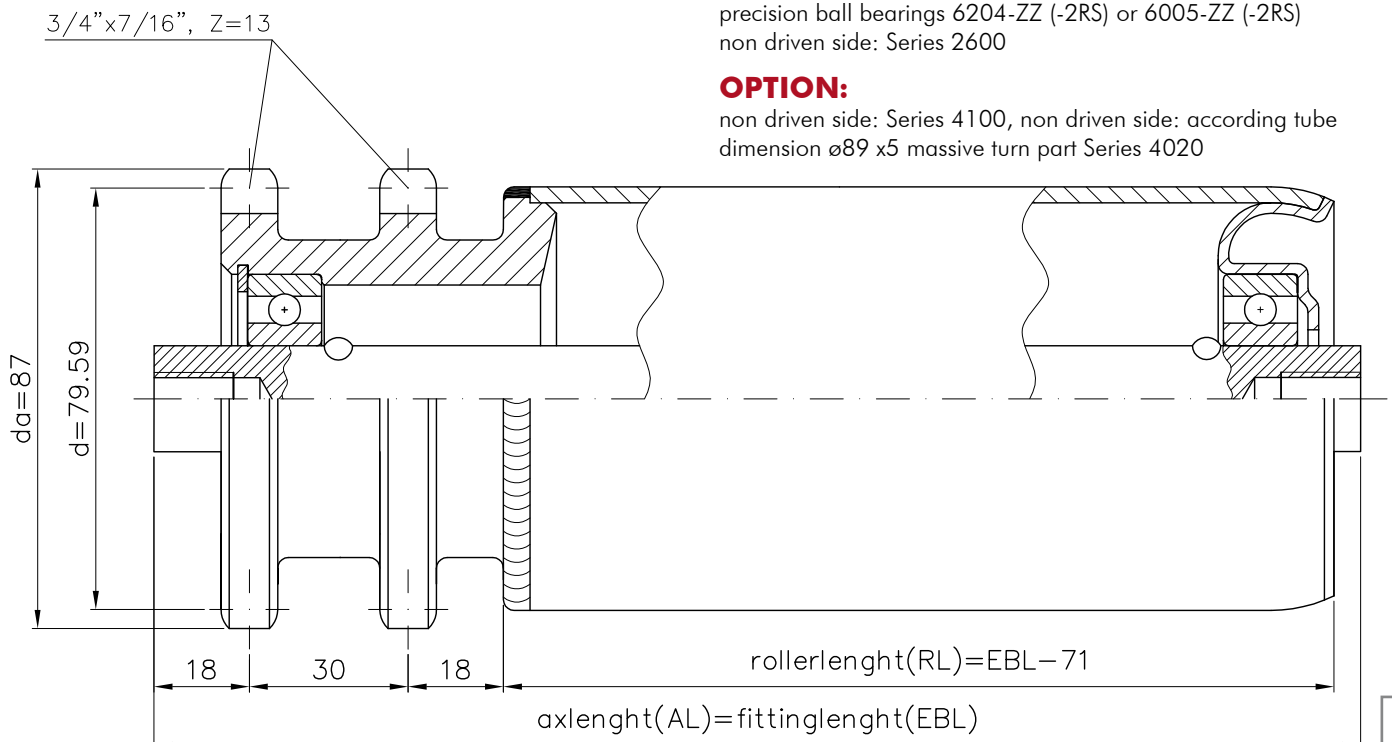

CONICAL ROLLERS

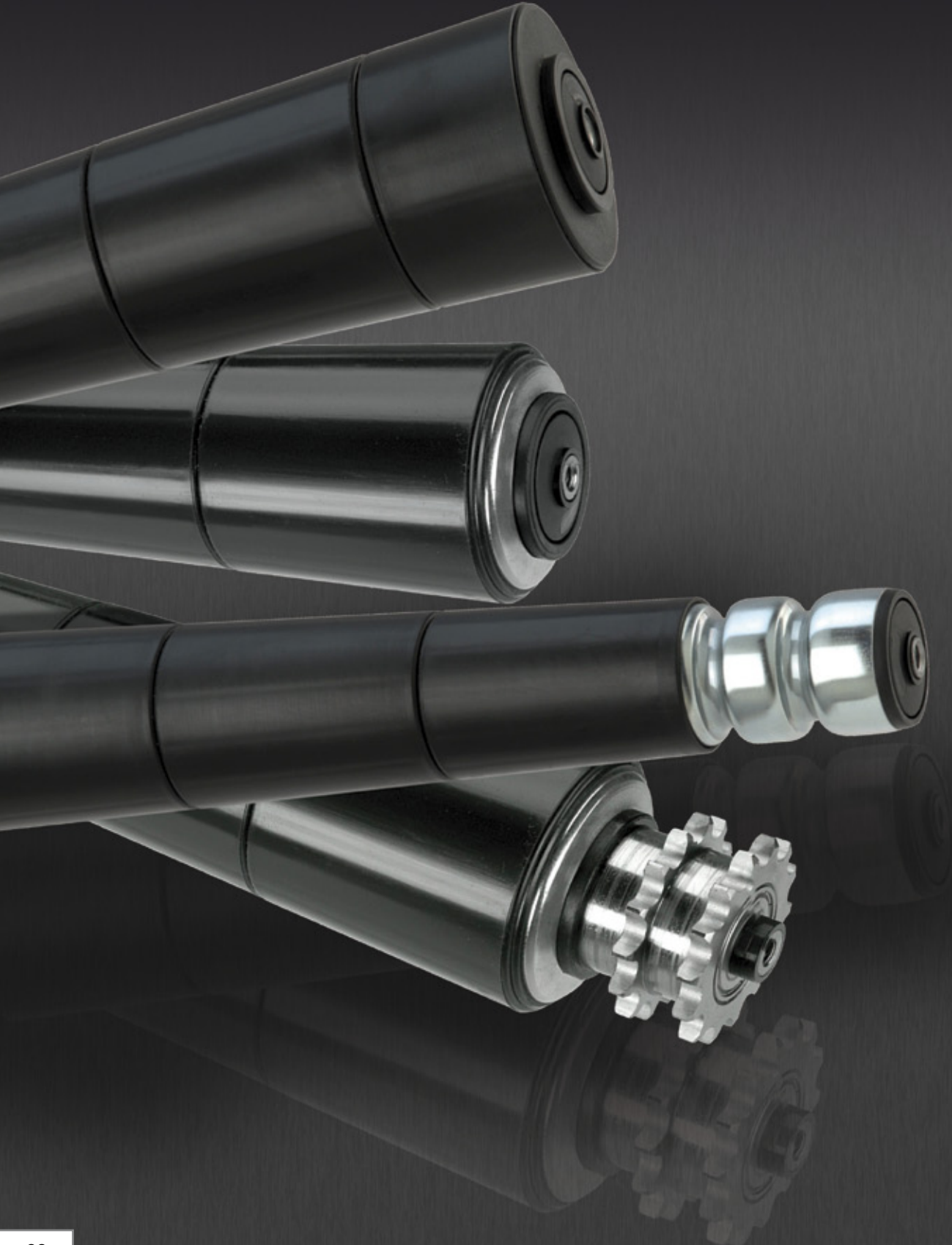



SERIES 6000, SERIES 6020 SERIES 6560, SERIES 6040

SERIES 6000 - CONSTRUCTION WITH INTERNAL THREAD						
tube- ϕ (mm)	axle- ϕ (mm)	8	10	12	14	15
ϕ 50	external thread:	M 5x15	M 6x15	M 8x15	M 10x15	M 10x15
	tubelenght =	EBL -15				
	rollerlenght =	EBL -15				
	axlelenght =	EBL				

SERIES 6020 - CONSTRUCTION WITH INTERNAL THREAD						
tube- ϕ (mm)	axle- ϕ (mm)	8	10	12	14	15
ϕ 50	internal thread:	M 5x15	M 6x15	M 8x15	M 10x15	M 10x15
	tubelenght =	EBL -69				
	rollerlenght =	EBL -63				
	axlelenght =	EBL				

SERIES 6560 - CONSTRUCTION WITH INTERNAL THREAD						
tube- ϕ (mm)	axle- ϕ (mm)	8	10	12	14	15
ϕ 50	external thread:	M 5x15	M 6x15	M 8x15	M 10x15	M 10x15
	tubelenght =	EBL -15				
	rollerlenght =	EBL -15				
	axlelenght =	EBL				

SERIES 6040 - CONSTRUCTION WITH INTERNAL THREAD						
tube- ϕ (mm)	axle- ϕ (mm)	8	10	12	14	15
ϕ 50	internal thread:	M 5x15	M 6x15	M 8x15	M 10x15	M 10x15
	tubelenght =	EBL -57				
	rollerlenght =	EBL -47				
	axlelenght =	EBL				

ADVANTAGES:

- tapered conveyor rollers secure transported material in curves
- Anti-static carrying roller
- Additional labyrinth seal offers protection from water spray and coarse dust
- Noise absorbing
- many possible combinations

APPLICATION:

- For in-plant conveyor systems
- Temperature-resistant from -10°C to + 40°C

MAX. DYNAMIC CARRYING CAPACITY:

- 0,8 kN

MAX. CONVEYOR SPEED

1,2 m/s

TUBE DIMENSIONS:

galvanized steel tube in accordance with DIN 2394 dimension ϕ 50 x 1.5 mm
with pressed conical PVC elements in black
optional: V2A-tube: ϕ 50 x 1,5

AXLE:

plain steel ϕ 10, ϕ 12, ϕ 14, SK11
Design: internal thread, external thread, spring axle, rigid axle, axle with width across flats. Optional V2A-axle

BEARINGS:

Synthetic bearing plate with precision deep groove ball bearings 6202-ZZ (-2RS) and labyrinth seal

DRIVE:

- Series 6560 standard size for the grooves:
A = 40, B = 30 for round belt ϕ 5 mm
- Series 6020 double chain wheel 1/2" x 5/16"
number of teeth = 14 steel or PVC
- Series 6040 with Multi W head 9 ribs

1/2"x5/16", Z=14

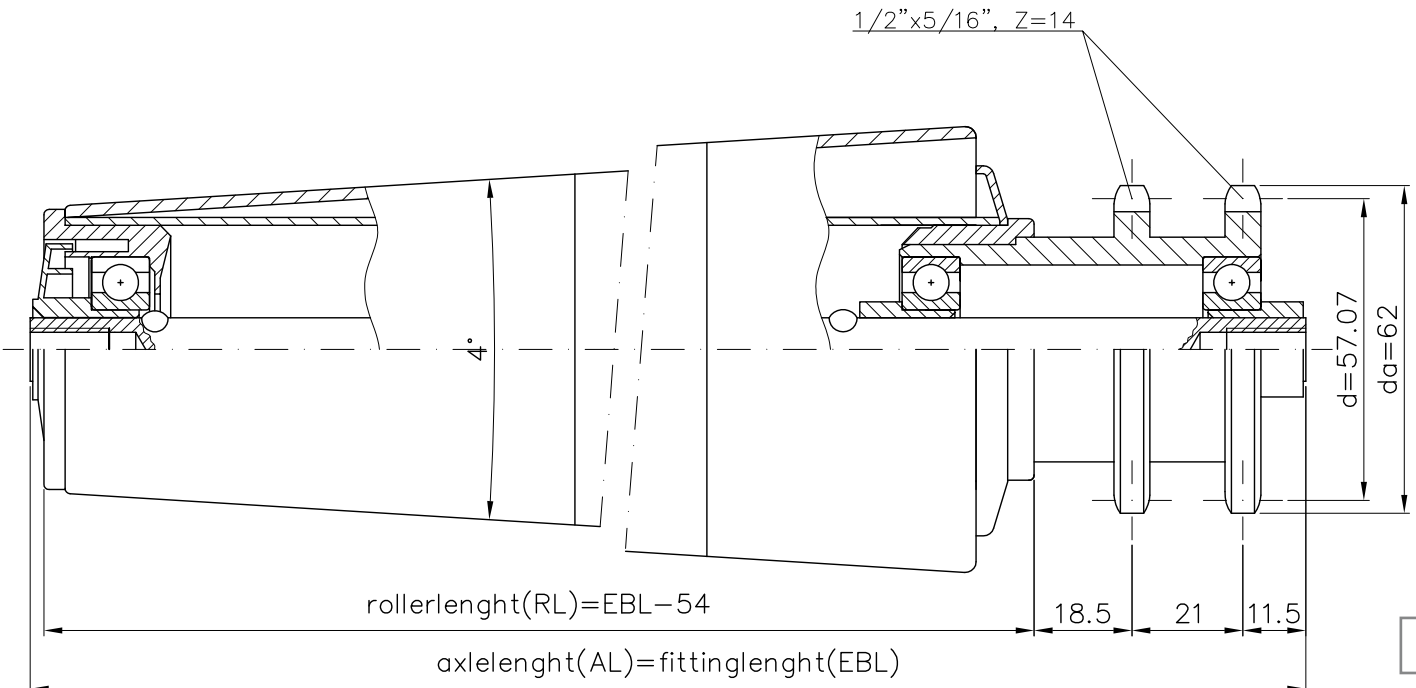

SPECIAL ORDERS

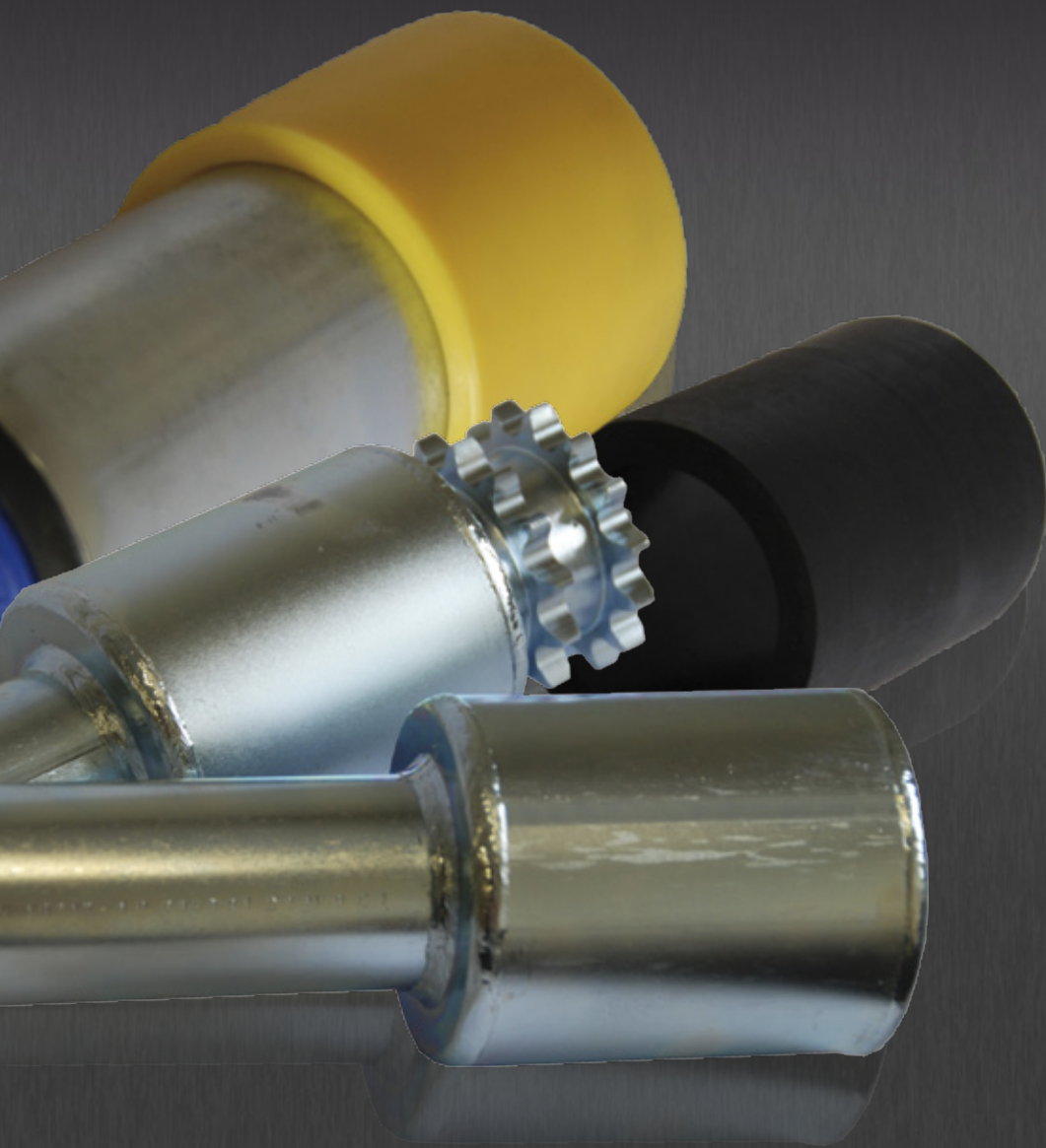

DRIVE ROLLERS



OMEGA 50

DRIVE ROLLER OMEGA 50:

The new OMEGA 50 motor roller was developed specifically for the transport of containers, trays and boxes up to a transport weight of 50 kg. Known disadvantages of drive rollers with gears were eliminated by the use of integrated intelligence. Latest technologies increase your system availability, economy, efficiency and thereby increase your profits.

INNOVATION:

Reduction of vulnerable mechanical components, the use of high-availability components and an innovative control concept guarantee a long life and high system availability. The drive is directly on the roller conveyor axle. This eliminates the intermediate positioning of inefficient gears prone to wear and tear. We follow the current trend of direct drive technology...

...and pass those benefits right on to you.

ADVANTAGES:

- Increased functionality through reduced component count, no gear
- Low power consumption, high efficiency, energy recovery
- Maximum efficiency, almost no wear parts, unmatched reliability
- Faster cycle times, up to 2000 cycles/h
- Increased availability, service life > 25000h
- Virtually silent operation: < 45 dB

CONTROL BOARD „LOGICARD“

The implementation of control functions or the power supply of the motor roller can be carried out by the electronics control board „LogiCard.“ In addition to signal processing of the target speed value, the direction of rotation, and error messages, the LogiCard also implements the logistic sequences **single transfer**, **train transfer**, **single release** and **train release**. To implement these logistic sequences, the respectively associated light barriers or sensors are connected directly to the LogiCard and the states „busy/free“ are returned and analyzed. Basically, there are two operating modes. Operated as a group, the signals are output by a higher-level PLC. In stand-alone operation, the speed and rotation direction is based on the setting of an integrated switch on the LogiCard.

MAXIMUM DYNAMIC LOAD CAPACITY

- Conveyor roller \varnothing 50 mm, max. load carrying capacity 50 kg

MAXIMUM CONVEYING SPEED

- 1.2 m/s with zero-pressure accumulation
- 2 m/s continuous operation

TUBE

- Steel tube acc. to DIN 2394, galvanized: \varnothing 50 x 1.5

AXLE

- Motor side: Plain steel \varnothing 12 with external thread M12x1 and SW10.5
- Opposite side: Internal thread M8

BEARING

- Precision grooved ball bearing 6202-ZZ (-2RS) and 6002-ZZ (-2RS)
- Temperature resistant from -10° to $+40^{\circ}$

DRIVE

- Series 4800 double chain wheel $1/2" \times 5/16" z = 14$; PVC, steel
- Series 4500 single chain wheel $1/2" \times 5/16" z = 11$; PVC, steel
- Series 4830 toothed belt HTD-8M $z = 20$ PVC
- Series 3760 round belt roller
- Series 3700 standard roller
- Conical motor rollers with / without drive optional

PROPERTIES

- Direct control or with „LogiCard“
- Rated voltage 24 VDC
- Connection: open end, optional plug-in or screw type, either M8 or M12
- Inputs for rotating direction and nominal parameters
- Output for error message
- minimal EBL = 200 mm, maximum EBL = 1400 mm
- Stall timing device
- Temperature protection
- CE certification, optional UL, cUL, CSA
- IP55 protection

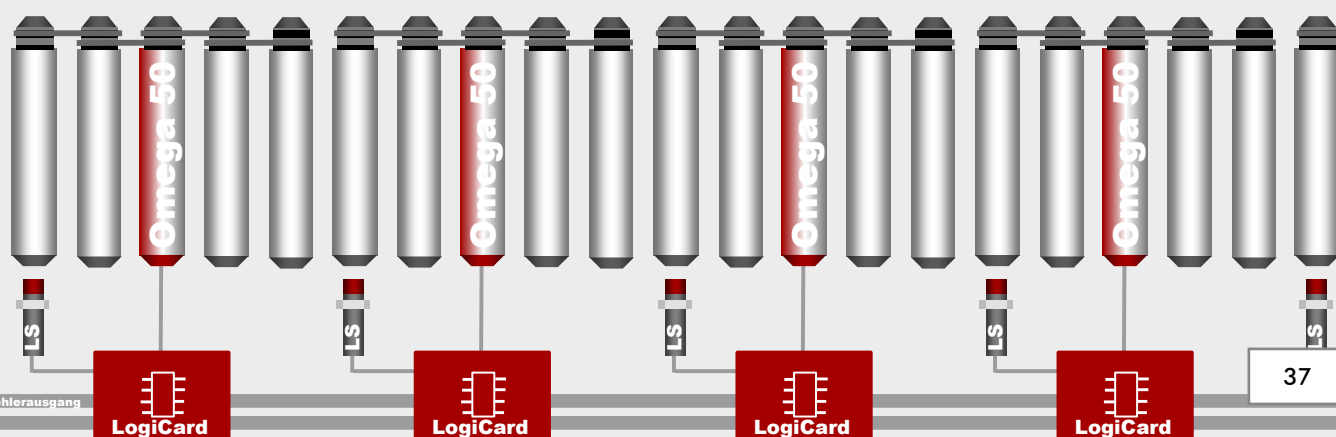

World Wide Web

Product data sheets are also available for download at www.kraus.co.at. Convince yourself of our expertise and our over 70 years of experience.



KRAUS
Eine Idee voraus

We get things rolling... **CONVEYOR ROLLERS**

KRAUS
Eine Idee voraus

MotorRolle Omega 50

Erhöhung der Lebensdauer
Die getriebene und verschleißfreie Variante, absolut wartungsfrei.
Increase the life cycle
Seamless, gearless, without wear parts, and absolutely maintenance free.

MOTORROLLE OMEGA 50:

Die neue Motorrolle OMEGA 50 wurde speziell für den Einsatz von Rollen, Kasken, Rollen und Rollen im Bereich der Transportrollen von 50kg entwickelt. Bekannte Nachteile von Antriebsrollen mit Getriebe werden durch den Einsatz innovativer Technologie, Moderner Technologien, Leistungsfähigkeit und hoher Ausdauer.

INNOVATION:

Erhöhung der Leistungsfähigkeit durch reduzierte Reibung, hochelastische Rollen und ein innovatives Erweitertes Getriebe. Der Einsatz der neuen Rollen führt zu einer Leistungssteigerung von bis zu 200%. Die Rollen sind wartungsfrei, langlebiger, leichter zu montieren und zu warten.

VORTEILE:

- Keine Wartung, kein Öl, kein Fett
- Kompakter Einbaubereich, sehr hoher Wirkungsgrad
- Hohe Lebensdauer, keine Verschleißteile, keine Ölverschmutzung
- Hohe Leistungsfähigkeit, bis zu 2000 U/min
- Hohe Flexibilität, Lebensdauer > 20.000h
- Hohe Flexibilität, Lebensdauer > 20.000h

DRIVE ROLLER OMEGA 50:

The new OMEGA 50 roller roller was developed specifically for the transport of containers, barrels, kegs and more. It is a transport roller of 50kg weight. It is designed to overcome the disadvantages of drive rollers with gears. It is designed to overcome the disadvantages of drive rollers with gears. It is designed to overcome the disadvantages of drive rollers with gears.

INNOVATION:

Erhöhung der Leistungsfähigkeit durch reduzierte Reibung, hochelastische Rollen und ein innovatives Erweitertes Getriebe. Der Einsatz der neuen Rollen führt zu einer Leistungssteigerung von bis zu 200%. Die Rollen sind wartungsfrei, langlebiger, leichter zu montieren und zu warten.

ADVANTAGES:

- No oil, no grease
- Compact installation, high efficiency
- Long service life, no wear parts, no oil contamination
- High performance, up to 2000 rpm
- High flexibility, service life > 20,000h
- High flexibility, service life > 20,000h

TRAGROLLEN
Conveyor rollers

Austria, Build for Europe

DOWNLOAD PRODUCT DATA SHEETS at www.kraus.co.at.

REQUEST FORM

By using the request form, we can find the optimal answer for your questions as well as the most efficient and effective solution. Your request will be answered within one business day.

Please fax your request form to 0043 (0) 463 38 60-21
or send your form by email to conveyroller@kraus.co.at

Company: _____

Street.: _____ Post Code, place.: _____

Field of activity: _____ Tel.: _____

Contact person: _____ Fax.: _____

Department: _____ E-Mail: _____

please fill in the correct design

Number of conveyor rollers: _____ pcs.

fitting length (distance between the profiles) EBL: _____ mm; rollerlength RL: _____ mm; axlelength AL: _____ mm

Driven roller gravity roller Drive roller

round belt taper roller if known Series of roller: _____

chain wheel or toothed belt pul Multi-W roller 9 rips for belt PJ

single double welded pressed for fixed move

_____ " x _____ " z= _____; or chain _____ B pressed for friction move

Bearing

easy run bearing precision ball bearing DIN Stainless steel V2A

labyrinthsealing cargo: _____

tube ø	thickness	tube material	axle ø	Design:	accessories/ extras:
20	1	steel galvanized	6	spring axle	precision ball bearing 2RS
30	1,5	plain steel	8	rigid axle	precision ball bearing inox
40	2	Sendzimir galv.	10	internal thread M:	flange rings pcs: ø
50	2,9	inox V2A	12	x	outside:
60	3	aloy	14	external thread M:	shrink fit sleeve PVC 63° Shore
63	3,25	PVC tube colour:	15	x	thickness:
80	3,6		17	width across flats:	impact rings or discs: TYP
89	5	chromed	20	x	
90	others:	others:	25	others:	gummed, thickness:
101,6			30		
108		axle material:	SK11	
133		plain steel			
159		steel galvanized			
others:		inox V2A			

weight capacity / roller : _____ kg temperature: _____ °C

customized roller (if possible send a drawing or sketch) V-belt others:

date: _____



KRAUS Betriebsausstattung und Fördertechnik GmbH

Phone: +43(0) 463/3860 - 68
Fax: +43(0) 463/3860 - 69
office@kraus.co.at

Sattnitzgasse 69
9020 Klagenfurt am Wörthersee
www.kraus.co.at